

• ***Gazar Valves*** •

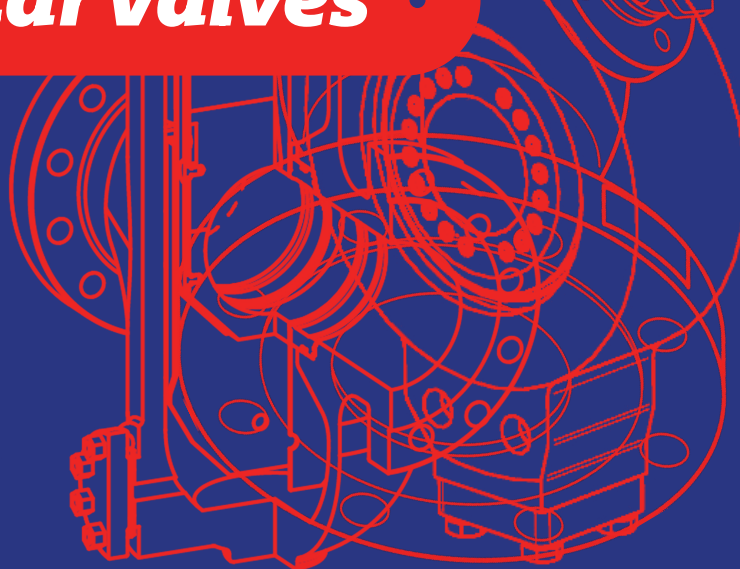

For All
Valve Applications



About Gazar

GAZAR, established in 2010, is a manufacturing company in IRAN fully designs, manufactures and markets of Industrial valves. Passion, knowledge, smart attitude and hard work allow us to propose and supply our Customers with the best solution for their needs. The development of new technologies, the know-how and the expertise of our team resulted in an ongoing success which makes us a reliable supplier. Our target is to supply a high-performance Iranian product and a customized service, to make the difference.

Our products list is as follow:

Trunnion Ball Valves

- Top Entry Rising Stem Ball Valve Up to 20", Class up to #900 (Orbit Valve KV)
- Top Entry Ball Valve Size up to 36", class up to #600
- Side Entry Ball Valves Size Up to 56", class up to #600

Floating Ball Valves

- Ball Valves Size up to 12", class up to #150.

Buried Plug Valve for Blow Down Valves

- Plug Valve up to 24", Class up to #600.

Rotary & Globe Control Valve

- Rotary (Ball or Butterfly valve) up to 56", class up to 600.
- Globe control valve up to 24", class up to #1500.

Single Offset Butterfly Valve F.E

- Single offset butterfly valves up to 56", class up to #900.

Double offset Butterfly Valve F.E

- Double offset butterfly valves up to 56", class up to #900.

Triple offset Butterfly Valve F.E

- Triple offset butterfly valves up to 56", class up to #900.

General Type Butterfly Valve F.E

- General Type butterfly valve up to 56", class up to #900.

Through Conduit Gate Valve F.E & W.E

- Through Conduit Gate Valve up to 42", class up to #600

Check Valve

- Swing, Dual plate, Axial Flow up to 36", Class up to #600

Supplied to the Oil & Gas, Petrochemical, Chemical, Marine, LNG & Power Generation, Onshore & Offshore Industries, on topside and subsea installations all over the world.

Our interest to our Customer's needs, our efforts to convert them in the best product, supported by the compliance to API, ISO & IPS/IGS regulations/accreditations, ensure the supply of a customized high-quality service, performed by experienced personnel. The ever-changing needs of our Customers make the GAZAR Engineering & Production Team work to offer a continuous innovation and an improved valve range year after year.

Each step of valve engineering and manufacturing can be validated using advanced software (AutoCAD, Solid Works 3D) through Finite Element Analysis of loads, tensions and deformations and final Stress tests, according to the applicable International Standards

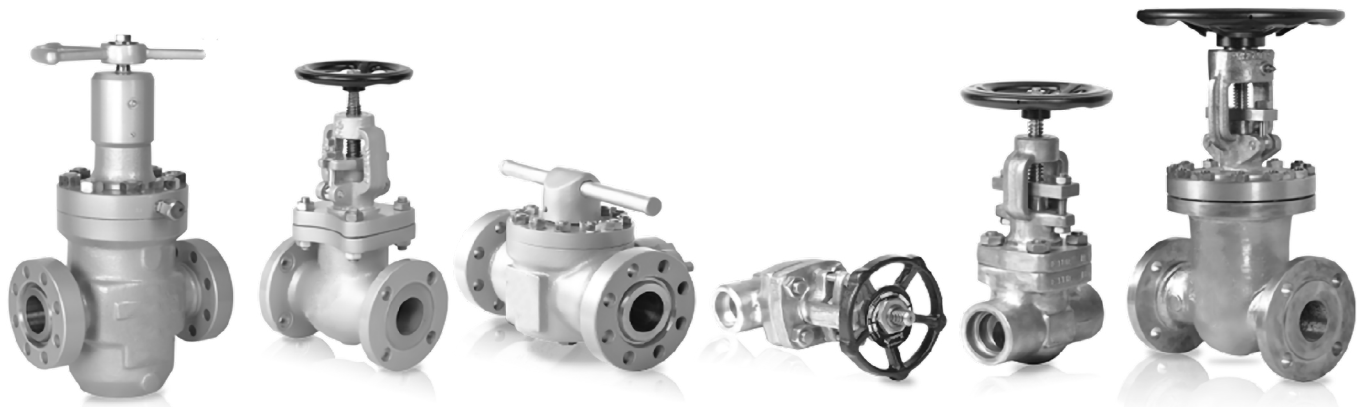

Rising Stem Ball Valves

No Rubbing Between Sealing Surfaces

The tilt-and-turn action eliminates seal abrasion, which is the major cause of seat wear in conventional Ball, Gate and plug valves.

Injectable Packing

For in-service maintenance, stem packing material is injected through the packing fitting, giving complete control of fugitive emission. (Available on all enclosed bonnet models.)

Single- Seat Design

The single, stationary seat in the ORBIT valves seal in both directions and avoids the problem of trapped pressure between seats.

Long Life

ORBIT valves replace troublesome Ball valves, Gate valves, Globe Valves and Plug Valves. The ORBIT design has performance advantages that reduce plant outage and reduce the cost of ownership.

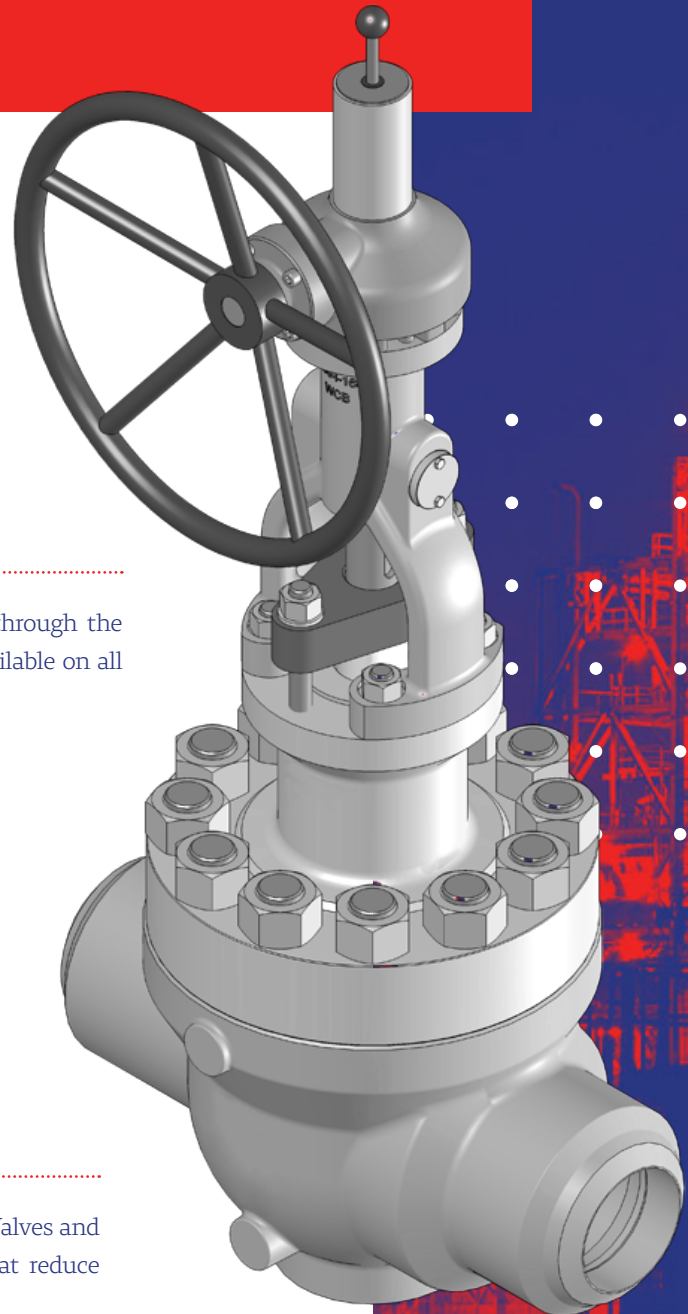

Optimum Flow

Full port or reduce port Openings Give high C_v Figures. System pumping efficiency is enhanced And Erosion problems are reduced.

Top-entry Design

In-line inspection and repair, after system Depressurizing, simplifies maintenance.

Dual Stem Guides

Hardened stem slots and tough guide pins Control the lift-and-turn action of the Stem.

Self-Cleaning

Tilting the core away from the seat before rotation causes Immediate flow around 360 degrees of the core face. Product Flow flushes any foreign material away from the seat without localized, high velocity erosive flow.

Low-torque operation

ORBIT valves turn easily because seal rubbing is eliminated.

Wear-resistance Hard facing on Core

The Core face is hard, polished material that will endure difficult service, without loss of sealing integrity.

Mechanical Cam Closure

The Cam angle at the lower end of the stem provides a mechanically energized seal.

- **Note:** Never remove any part from and ORBIT valve unless specifically instructed to do so in the literature, or without first consulting a Cameron representative. Incorrect Procedure could result in personal injury and/or property damage.



GAZAR

Rising Stem Ball Valve (Single Seat)

Specifications: Top Entry (2 Pieces) | Flanged Ends
Full Port | Trunnion mounted | One piece stem
valves, enclosed bonnet

S T A N D A R D

Face to Face Dimension ANSI B16.10

End Flange Dimension ANSI B16.5

Design ANSI B16.34

Basic Design API608 / API6D

Fire Safe Design API607

- 1 Stem Protector
- 2 Handwheel
- 3 Position Indicator Rod
- 4 Position Indicator Rod Nut
- 5 Bonnet Nut
- 6 Set Screw
- 7 Needle Bearing
- 8 Bearing Race
- 9 Drive Nut
- 10 Stem
- 11 Stem Guide Nut
- 12 Stem Guide
- 13 Grease Nipple
- 14 Bonnet
- 15 Packing Fitting
- 16 Packing Chamber Bushing
- 17 Lantern Ring
- 18 Packing Ring
- 19 Bonnet Bushing
- 20 Body Stud Nut
- 21 Body Stud Bolt
- 22 Core
- 23 Trunnion Bushing
- 24 Seat Ring
- 25 Body

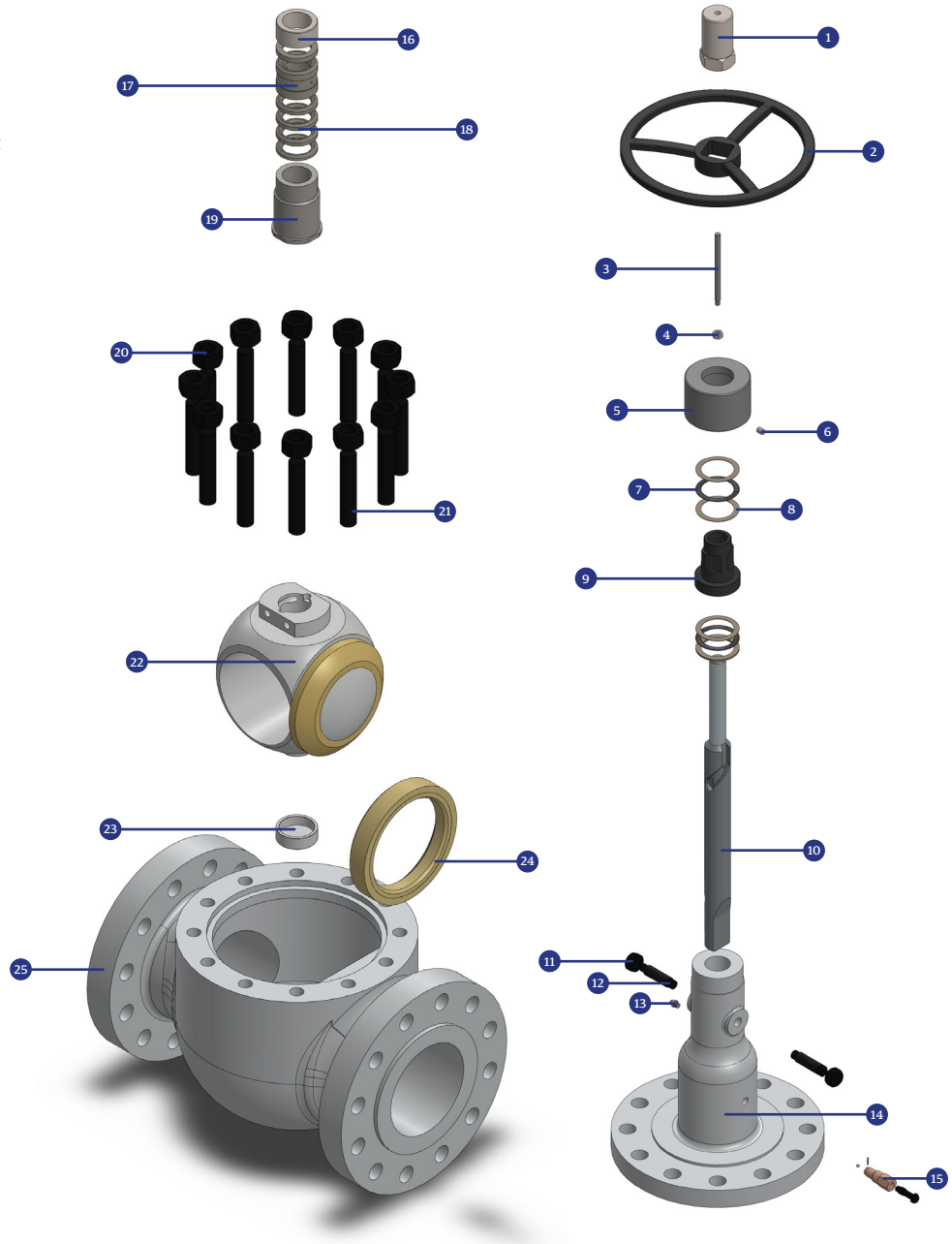

About Trunnion Ball Valves

Trunnion ball valves have the obturator bounded by Trunnion which do not allow axial displacements of the ball itself in the flow direction; line pressure compresses the seat onto the ball, the contact between surfaces generates the valve sealing. Trunnion standard construction ensures automatic cavity relief in case of overpressure in the body cavity; these valves can be selected for a wide range of applications with no specific limits to sizes and pressures.





GAZAR Trunnion Ball Valve Production are mainly designed to conform API 6D (Specification for pipeline valves) and ANSI B16.34 (Valves Flanged, Threaded and Welding End) or API 6A (Specification for Wellhead and Christmas Tree Equipment) in case of upstream applications. Other related standards such as ANSI B16.5 (Pipe Flanges and Flanged Fittings), ANSI B16.25 (Butt-welding Ends), and ANSI B16.10 (Face to Face and End-to-End Dimensions of Valves) are also used for the design of ball valves. Also our ball valves are designed to meet FIRE SAFE requirements to BS6755, API 6FA and API 607.

Final testing is done to conform API 598 (Valve Inspection and Testing) MSS-SP-61 (Pressure Testing of Steel Valves) API6D (Specification for Pipeline Valves) or API 6A (Specification for Wellhead and Christmas Tree Equipment) requirements. Materials are selected mainly to ASTM standards and when sour service is specified to meet NACE MR-01-75 (Sulfide Stress cracking resistant Metallic Materials for Oilfield Equipment).

Bi-directional Flow

GAZAR ball valves are suitable for bi-directional Sealing.

Soft Seated Valves

The seat design features a deep pocket with a protective lip which makes the design a long lasting design. The seat assembly consists in an outer metallic seat carrier with a soft seat insert. The soft insert is located into a groove in the metallic seat carrier. The complete seat assembly is floating inside valve body and it is energized by a set of springs which load the seat assembly against the ball preventing leakage from behind the seat. Seat assembly is provided with outer O-ring to avoid leakage through the seat carrier and a graphite backup ring which ensure the tightness in case the O-ring is damaged.

Metal Seated Valves

Similar seat construction is done in case of metal seated valve. However the seat in this case consists only in a metallic seat ring (without any insert). The surface in contact with the ball is hard faced with Tungsten Carbide, stellite etc., achieving a minimum hardness of 42 HRC to stellite or conventional hard faced and 78 HRC to Tungsten Carbide or special hard faced. This makes the design long durable and reliable and able to achieve classes V & VI leakage class.

Trunnion Design for Low Torque Operation

Similar seat construction is done in case of metal seated valve. However the seat in this case consists only in a metallic seat ring (without any insert). The surface in contact with the ball is hard faced with Tungsten Carbide, stellite etc., achieving a minimum hardness of 42 HRC to stellite or convectional hard faced and 78 HRC to Tungsten Carbide or special hard faced. This makes the design long durable and reliable and able to achieve classes V & VI leakage class.

Stem Extension for Buried Service

A stem extension is a need when valves are being installed in underground pipeline making the valve operator non accessible. GAZAR offer a wide variety of stem extensions for manual operated valves as well as for actuated valves, including gas over-Oil operated valves. The stem extension includes the complete system of grease injection, actuator gas supply, etc. as a part of it.

Specification

Size Range: 2" - 56" | Pressure Class: ASME 150 - 900 API 2000 -15000 | API Standards: 6D & 6A | API 6D SS | ASME B16.34

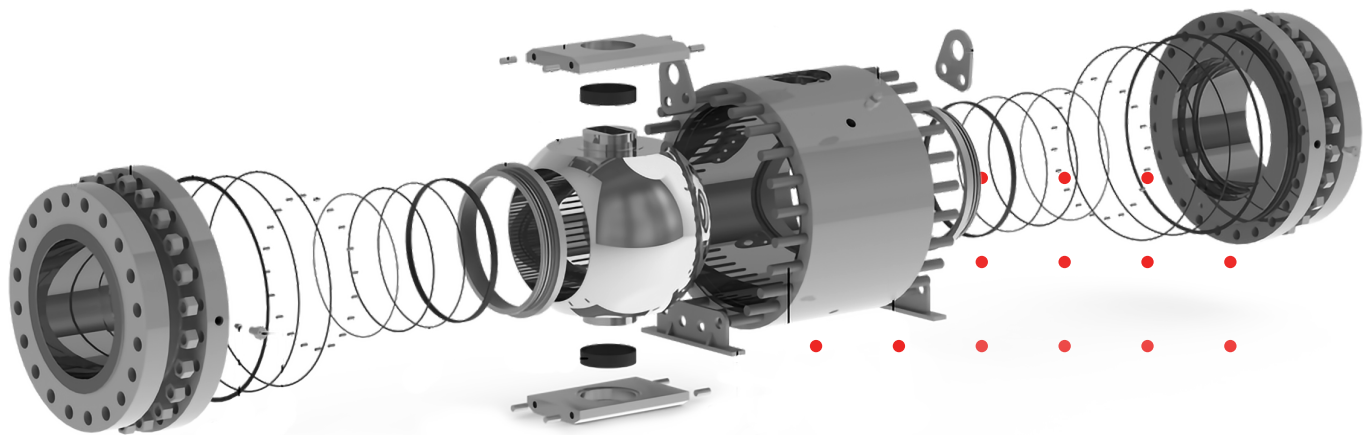

Fully Welded & Split Body Ball Valve

GAZAR Fully Welded & Split Body Valves are used in pipelines and pumping compression stations As well as subsea applications. Our welded design reduces the leakage path And makes the valves ideal for underground and subsea installations. Welding of the two or three piece body parts are performed with a special Technique so that post welding heat treatment is not required and soft Seals are not subject to damage during the welding. The extensive size range and pressure class are available in a Variety of materials including Carbon, Alloy & Stainless steel Suitable for general to severe service conditions. Our Split body design, size range and pressure class are Available in a variety of materials including Carbon, Alloy & Stainless steel suitable for general to severe service conditions.

- **Size Range:** 2" - 56"
- **Pressure Class:** ASME 150 - 900
- **API Standards:** 6D & 6DSS & 6A, ASME: B16.34

Features



Piece Body | Full And Reduced Bore | Trunnion Mounted | Double Block And Bleed | Single Or Double Piston Effect Design | Anti-blow Out Stem | Anti-static Device | Firesafe To Api-607 / 6FA / Iso 10497 | Spring Loaded Seats | Sealant Injection | Nace Mr-01-75

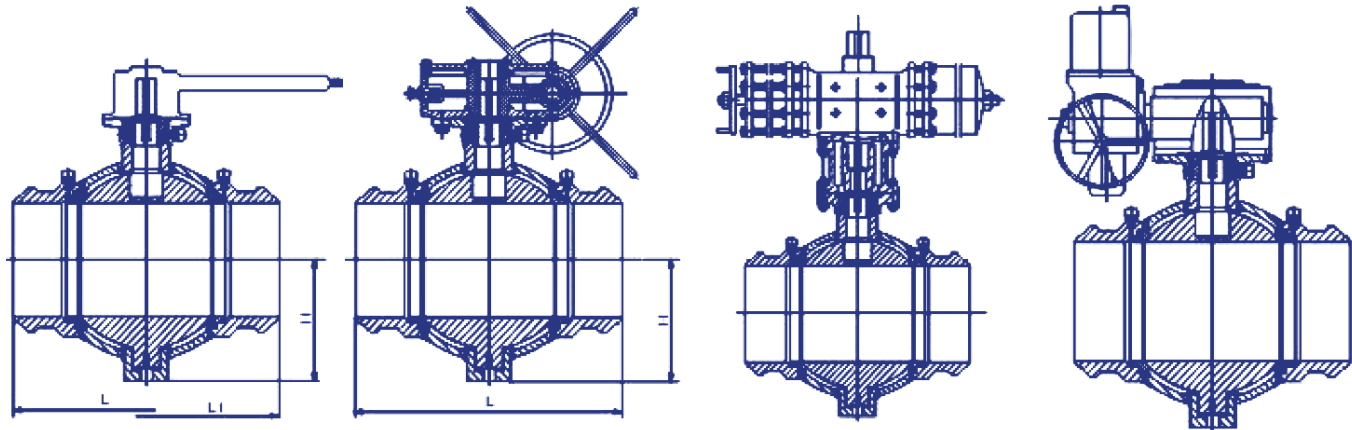



Top Entry Ball Valve

Top Entry Ball valves are used in pipelines, pumping and compression stations, offshore, onshore, subsea and cryogenic as well as Abrasive and high temp applications. The Top Entry design permits full repair in line and also allows the valve to be welded in line allowing easy maintenance. The cast or forged one piece body and bolted bonnet allows for the use of a full range of materials including Carbon, Alloy & Stainless steel suitable for general to severe service conditions.

Valve Material



GAZAR valves are manufactured using a wide selection of materials such as:

- Carbon steel
- Killed carbon steel for low temperature applications
- High resistance alloy steels for API 6A applications
- Stainless Steel
- Duplex & Super duplex steel
- Nickel alloys

Materials also meet the requirements of NACE MR-0175/ISO 15156 when sour gas services are specified. Our technical staff is ready and available to provide customized material selection for those special customer applications. GAZAR always provides the customer with suitable information of material selection which is agreed prior valves are manufactured.

Seat Principle:

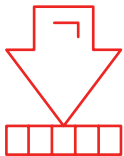

1. Two independent seat rings grant the sealing barrier against the line pressure acting on the upstream and downstream sides of the valve which allows the valve to be bidirectional. **2.** A set of coil springs acting between the upstream side of each seat ring and the body, generate an uniform thrust on the seat which push the same against the ball and grant the sealing feature with no or very low pressure in the line, when the line pressure increase the thrust acting on the seat increases proportionally and the sealing feature is granted throughout the full pressure range. **3.** The GAZAR trunnion mounted ball valves **4.** Are available with Double Block & Bleed independent of the seat type.

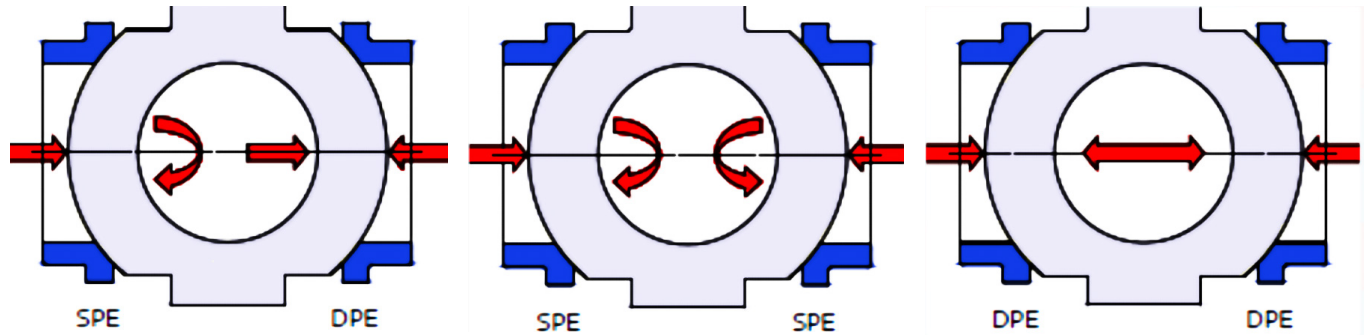

Seat Design	Single Piston Effect (SPE)	Single Piston Effect (DPE) - DIB ¹	Combined DIB ¹
Bi-Directional Sealing	Yes	Yes	Yes
Body-Cavity Self-Relieving	Yes	No	Yes
Double Barrier	No	No	Yes (Perferred Direction Only)

Single Piston Effect



Single piston effect (SPE) is the standard feature for the seat rings of the SADRA MAHAN PARSIAN (GAZAR) trunnion mounted ball valves. The pressure acting on the upstream side of the seat ring generates a force which push the seat towards the ball. The pressure acting on the downstream side of the seat ring generates a force which pull the seat ring away from the ball. Any overpressure which may be generated by the thermal expansion of the fluid trapped in the body cavity with the ball in fully closed position, will be automatically discharged in the line on the lower pressure side.

Double Piston Effect



Double piston effect (DPE) is a standard feature for the seat rings of the GAZAR trunnion mounted ball valves & recommended for welded body valves. On a DPE seat ring, both the pressure acting on the upstream side of the seat ring and the pressure acting on the downstream side of the seat ring, generate a force which push the seat towards the ball.

With this type of seat ring, the eventual overpressure which may be generated by the thermal expansion of the fluid trapped in the body cavity with the ball in fully closed position, can be discharged by the use of, an external safety relief device. The Double Piston Effect grants a double sealing feature, if the upstream seat ring is damaged, the downstream seat grant the sealing feature of the valve.

Fire Safe



GAZAR complete range of Side entry, Top Entry and Welded body ball valves are certified fire safe according to API 607 / ISO 10497 - API 6 FA.

Valves Ends

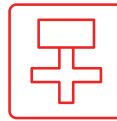

Valves are available with:

- Flanged Ends (RF or RTJ) to ASME B16.5 or ASME B16.47
- Welding Ends to ASME B16.25 Hub End

Bore



Valve can be supplied with Full or Reduced bore in accordance with table 1 of API 6D, unless otherwise required or advised. Valves with special Bore are available.

Face to Face/End to End



Dimensions are in accordance with API 6D and ASME B16.10. Special dimensions are available.





Valve Transition Pieces



Transition pieces (pups), can be supplied for Welding Ends Valves to facilitate the welding of the valve to the line for:

- Material compatibility.
- Excessive difference in strengths and thickness between valve closures and line pipe (limit is 1,5 times).
- Avoiding damages to the valve soft seals.

Important note: when transition pieces are supplied by the customers, it is imperative to verify if the strength of the Same, suitable to undergo the hydrotest of the valve without damages or deformations (1.5 times the valve maximum rated pressure).

Weld Overlays



Welded overlays, with Stainless Steel, Duplex and Inconel are available on request for:

- All wetted parts
- Body wetted parts
- Seat rings housing pocket
- Stem sealing area
- Balls

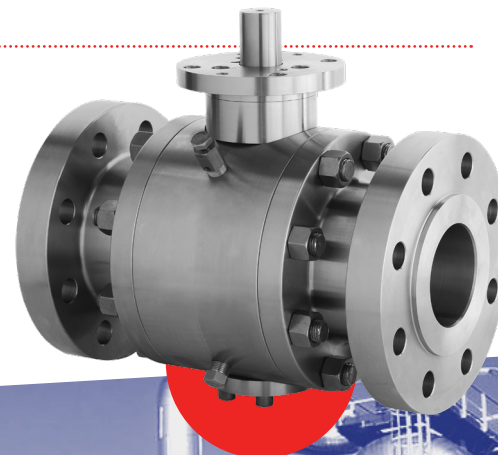



GAZAR Ball Valve Trunnion mounted (Double seat) (Size 1 1/2" to 4")

Specifications: Side Entry (3 Pieces) | Flanged Ends
| Full Bore

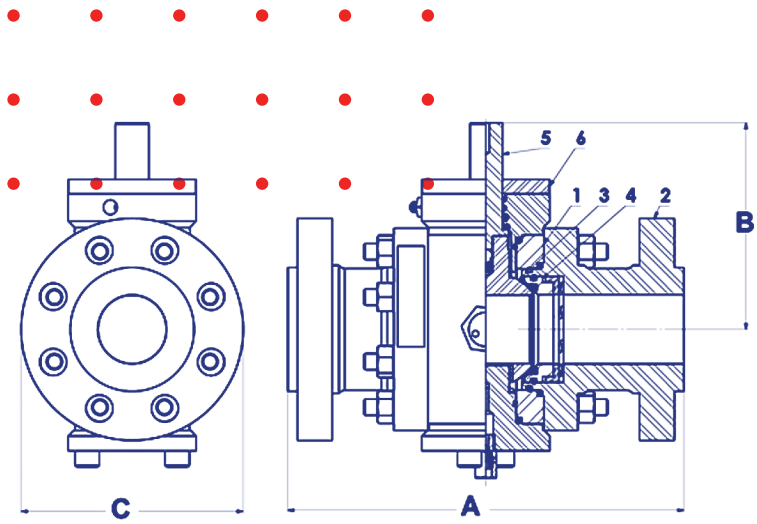

S T A N D A R D

Face to Face Dimension	ANSI B16.10
End Flange Dimension	ANSI B16.5
Design	ANSI B16.34
Basic Design	API608 / API6D
Fire Safe Design	API607



GAZAR Ball Valve Trunnion mounted (Double seat) (Size 6" to 60")

Specifications: Side Entry (3 Pieces) | Flanged Ends
| Full Bore

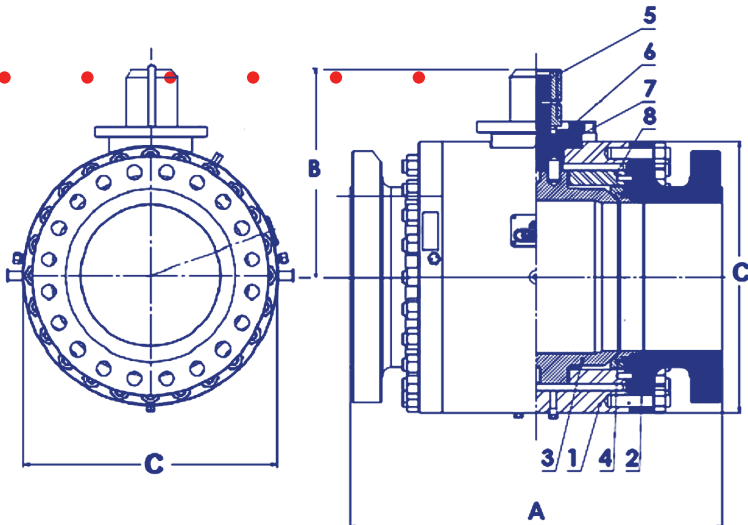
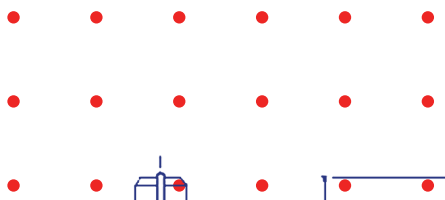

S T A N D A R D

Face to Face Dimension	ANSI B16.10
End Flange Dimension	ANSI B16.5
Design	ANSI B16.34, ANSI B16.34
Basic Design	API608 / API6D
Fire Safe Design	API607

About Floating Ball Valve

GAZAR Floating Ball Valves are available in an extensive range of designs, materials, sizes and pressure classes and are in full conformance with ANSI, API and NACE specifications. All ball valves are designed in accordance with ASME B16.34 and API 608 and where applicable with API 6D or BS EN ISO 17292. GAZAR uses only high-quality materials inspected & tested to International Standards and utilizes advanced manufacturing technology with special emphasis on safety, quality, and long service life of our products, to ensure that our clients receive the “best in class” products available from us at a competitive price and delivered on time. Forging material has increased strength under maximum rated operation pressure compared with cast. Other forging properties include greater impact resistance, resistance to fatigue cracking, particularly when cycling at either high or Cryogenic temperature. Overdesigned wall thickness and adaptation of high strength tie bolts convenient for valve maintenance and sufficient pipe stress.



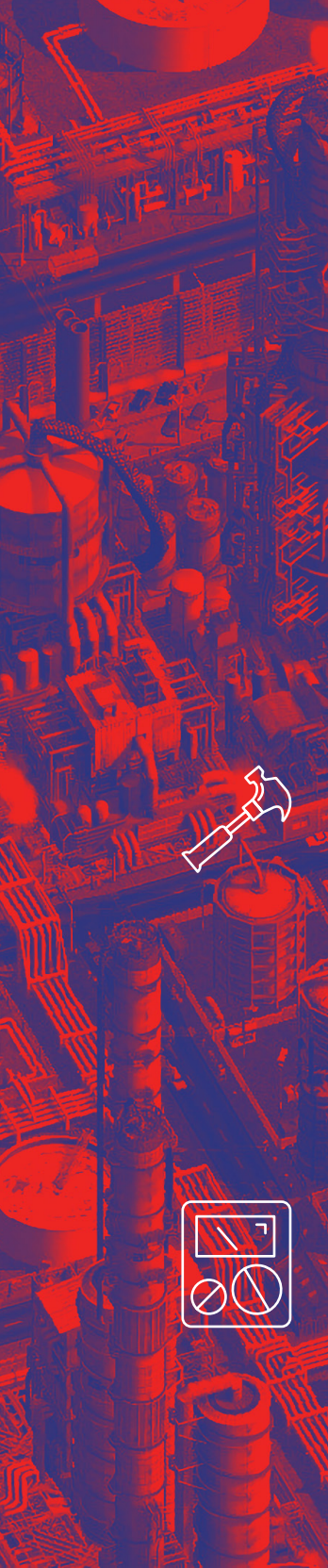

Ball valves are intended to be used as on/off flow control devices and are not to be used to throttle fluid flow. The valves should always be either fully open or closed.

GAZAR Floating Ball Valve design is developed using the latest software based analysis tools. At the design stage, all projects are analyzed using 3D solid modelling tools. Benefits include reduction of development time and cost, improved product quality, and ability to solve field problems for customers. Product flexibility and accuracy is assured.

Finite Element Analysis (FEA) is a very important step at the development stage to ensure the best possible performance requirements. Valves operational problems, pressure/temperature-related deformations and flow-related forces within a valve can be evaluated.

GAZAR uses the FEA for predicting failure due to unknown stresses by showing problem areas in a material and allowing designers to see all of the theoretical stresses within.



Computational Fluid Dynamics (CFD) is used to simulate operating flow conditions. Evaluation of Valve CV coefficient and convective heat transfer coefficient takes place at the design stage.

Main Features

- Fire-Safe Test Approved: GAZAR floating ball valves are designed in accordance with API 607 & API SPEC 6FA.
- Double Body Gasket
- Antic-Static Device
- Anti-Blow-Out Proof Stem
- Solid Ball
- Longevity of Life
- Low Torque Output

Inspection And Testing

Every valve is subjected on routine base to different non-destructive testing, like the dye penetrant test on butt weld ends, on all hard faced and cladding areas. Non-destructive test are also carried out on the critical areas as defined by ASME B16.34



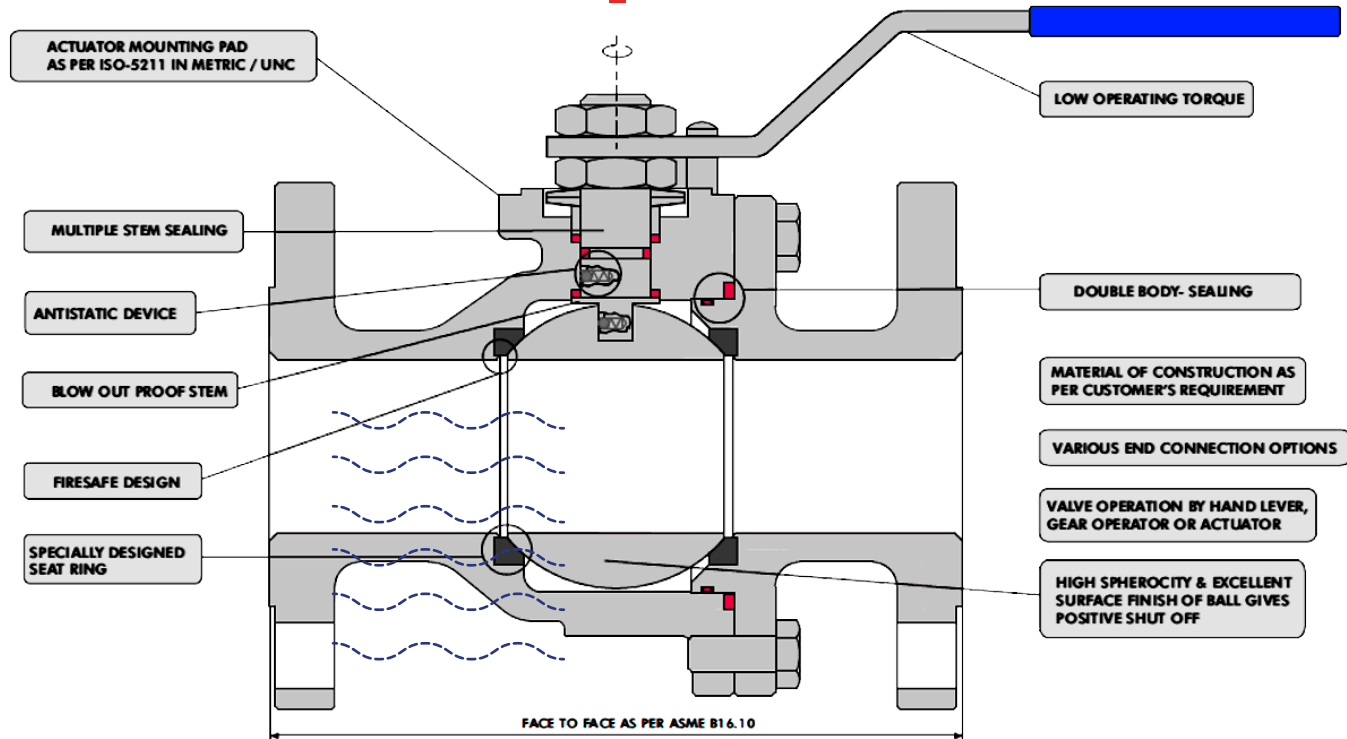

Marking And Identification



Each valve is identified on proper name plate and on valve body as required by MSS SP-25 and ASME B16.34. Name plate carries all information on rating, size, valve body and trim material, customer tags.

Fire Safe



Fire safe Conformance to API 6FA/ API 607/BS-6755 part II Assures highest standard of safety. Certified by Customer's Inspectors and independent certifying authorities.



• **GAZAR Ball Valve Floating (Double seat)** •

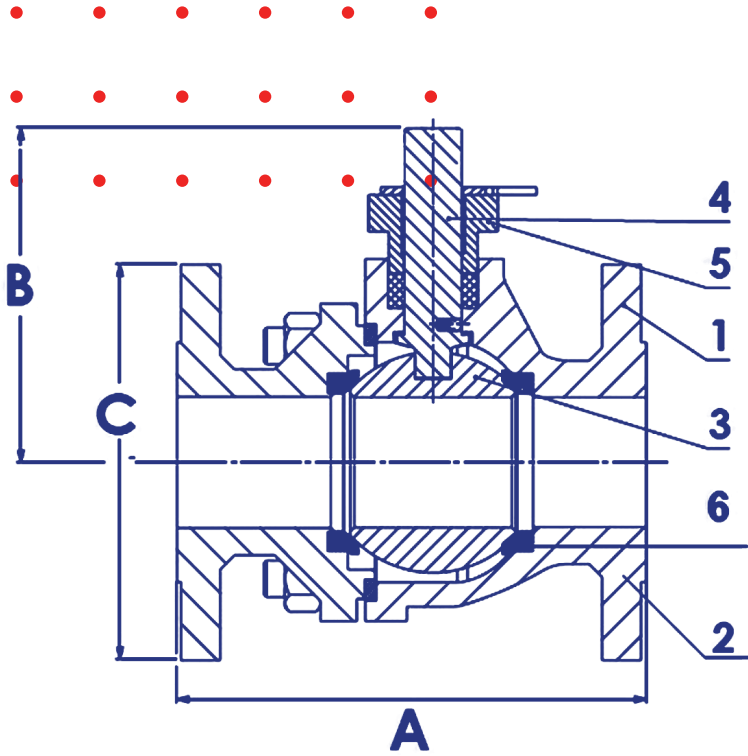

Specifications: Split Body | Flanged Ends | Full Bore

S T A N D A R D

Face to Face Dimension	ANSI B16.10
End Flange Dimension	ANSI B16.5
Design	ANSI B16.34
Basic Design	API608 / API6D
Fire Safe Design	API607



About Pressure Balance Plug Valve

A Plug Valve is a quarter-turn rotational motion Valve that use a tapered or cylindrical plug to stop or start flow. In the open position, the plug-passage is in one line with the inlet and outlet ports of the Valve body. If the plug 90° is rotated from the open position, the solid part of the plug blocks the port and stops flow. Plug valves are similar to Ball valves in operation.





Types of Plug valves

GAZAR Plug valves are available in a non-lubricated or lubricated design and with several styles of port openings. The port in the tapered plug is generally rectangular, but they are also available with round ports and diamond ports. Plug valves are also available with cylindrical plugs. The cylindrical plugs ensure greater port openings equal to or larger than the pipe flow area. GAZAR Lubricated Plug valves are provided with a cavity in the middle along their axis. This cavity is closed at the bottom and fitted with a sealant-injection fitting at the top. The sealant is injected into the cavity, and a Check Valve below the injection Fitting prevents the sealant from flowing in the reverse direction. The lubricant in effect becomes a structural part of the Valve, as it provides a flexible and renewable seat. No lubricated Plug valves contain an elastomeric body liner or a sleeve, which is installed in the body cavity. The tapered and polished plug acts like a wedge and presses the sleeve against the body. Thus, the nonmetallic sleeve reduces the friction between the plug and the body.

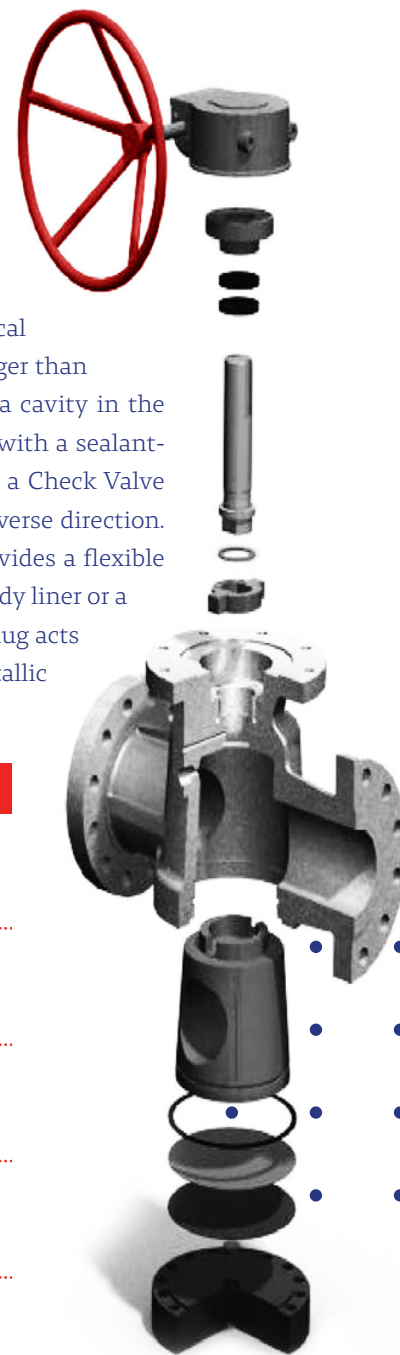

GAZAR Pressure Balance Plug Valve

Size

2" - 24"

Pressure Class

ASEM 150-2500

API Standard

API 6D, API 599

ASME

B16.10 & B16.5 & B 16.34

IGS

M-PL-02

Installation, Operating Instruction and Stress Analysis

Storage

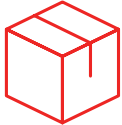

1. Valves must be stored in a dry and ventilate room and placed orderly. The stem can't bear any strength.
2. During the period of storage, the valve should be always on and inlet and outlet should be blocked.
3. During the period of storage, the outside portion of the stem and the machined surface should be covered by an easily cleaned antirust.

Installation



1. The valve can be installed freely, but it should be convenient to maintenance, inspection and operation.
2. Before installation, operators must review whether the contents on the marking and nameplate conform to the practical requirements.
3. Before installation, operators must clean the internal chamber and inspect whether studs between the body and the bonnet are fastened symmetrically, and pickings are dropped tightly symmetrically and the stem is bearing strength.
4. The flowing direction of the media is not restricted.
5. Mustn't take the worm gear box as the lifting eye to use.
6. After installation, valves must be blown and tested by the system pressure.
7. The practical condition intending to use valves must conform to the requirements specified on nameplate and in the operation instruction.
8. The valve only works for getting or shutting off media. Mustn't take it as the regulation valve.
9. The plug is turned through the hand wheel. Mustn't use any other assistant levers or drives to operate the valve.
10. During the period of using valves, the following projects must be inspected at an expected time. Once any noncompliance is found, please correct it right now.
 - a. Whether fasteners become less crowded or not.
 - b. Whether packing is worn out and gaskets are mangled or not. (Inspection without work)
 - c. Whether the actuator is flexible and there is the phenomena that valves can't turned.



- d. Whether the seal surface are mangled or worn out. (Inspection without work).
 - e. Whether leakage takes place at the cooperating position of the seat and the body or not. (Inspection without work)
 - f. Whether the wall thickness of valves becomes thin distinctly for corrosion or erosion or not. If the wall thickness is less than the net valuation only Satisfying the requirements of tensile strength or there exists a visually leakage, the valve must be scrapped.
- 11.** After valves are inspected and assembled, they are tested per responsible specifications and the records must be documented to refer to later.

The Static Stress Analysis

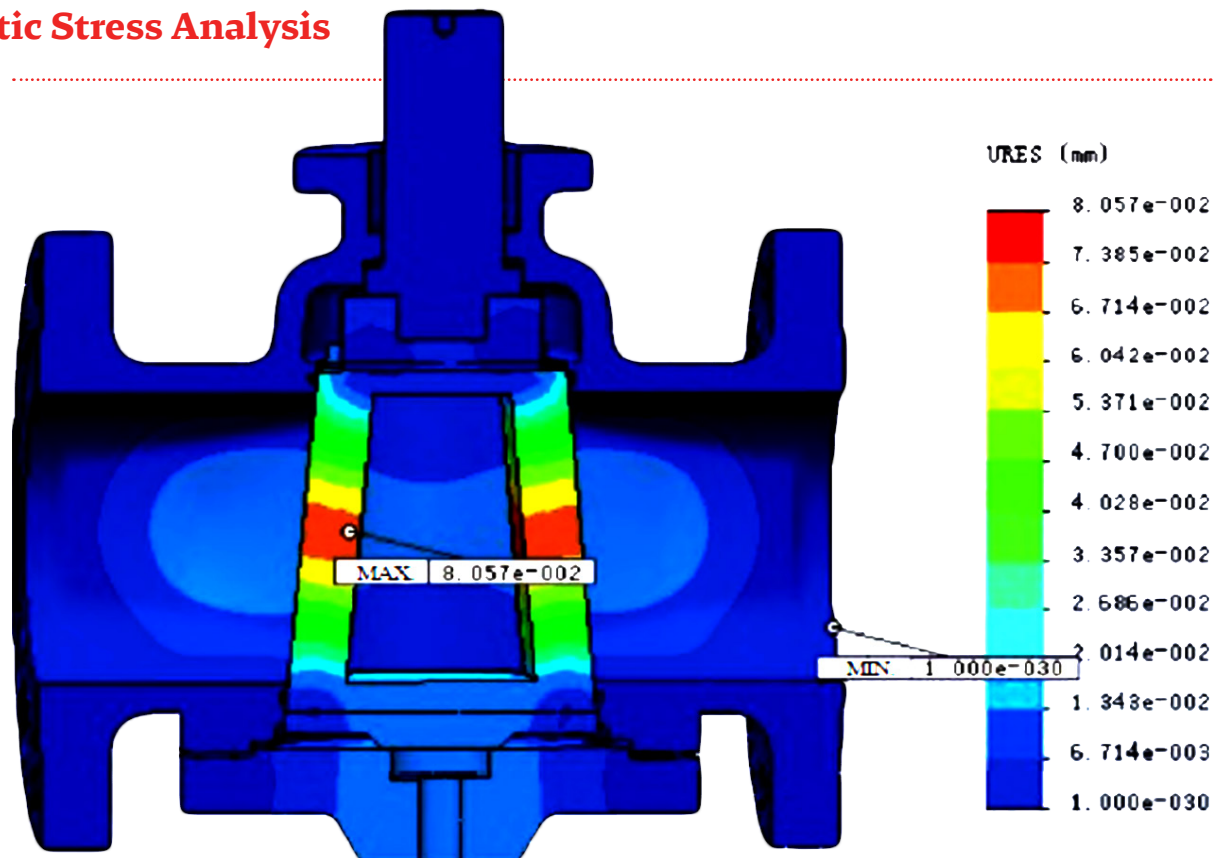

GAZAR Regular Pattern Plug Valve ANSI 150

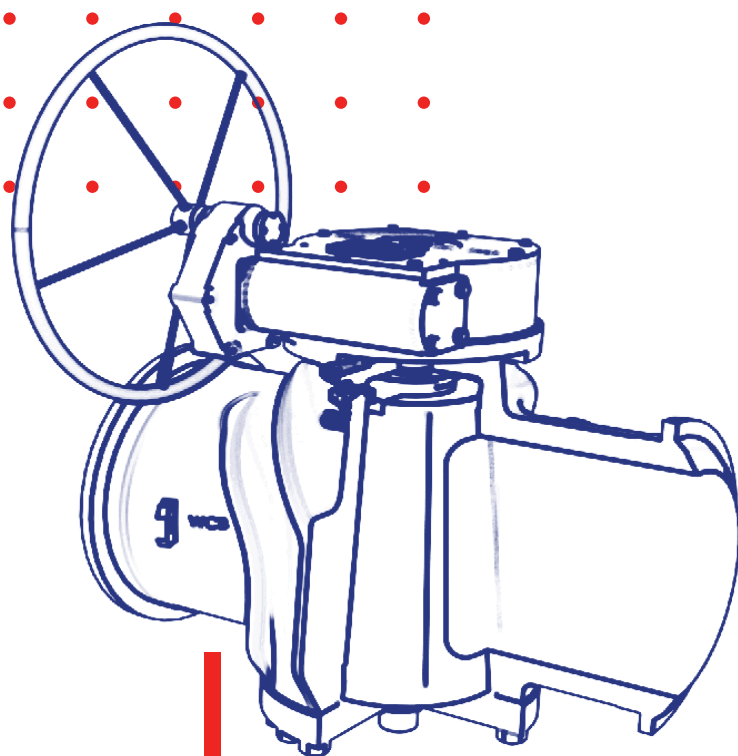

Specifications: Reverse Type | Regular Pattern | Wrench Operated & Gear Operated | Lubricated taper Plug valve

S T A N D A R D

Face to Face Dimension ANSI B16.10

End Flange Dimension ANSI B16.5, B16.34

Design ANSI B16.10, API 599

Basic Design ANSI API 6D

Test according API 598 & MSS. SP78

Fire Test API 6FA

GAZAR Regular Pattern Plug Valve ANSI 300

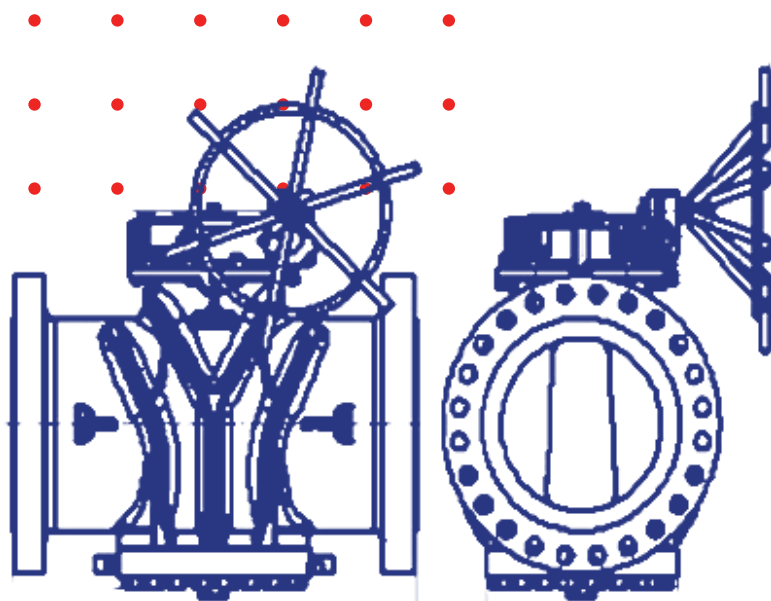

Specifications: Reverse Type | Regular Pattern | Wrench Operated & Gear Operated | Lubricated taper Plug valve

S T A N D A R D

Face to Face Dimension ANSI B16.10

End Flange Dimension ANSI B16.5, B16.34

Design ANSI B16.10, API 599

Basic Design ANSI API 6D

Test according API 598 & MSS. SP78

Fire Test API 6FA



• **GAZAR Regular Pattern Plug Valve ANSI 600** •

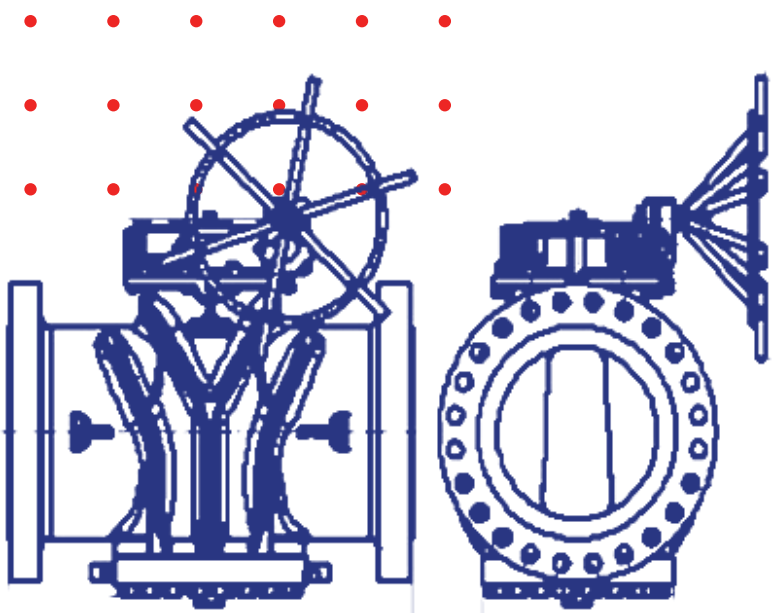

Specifications: Reverse Type | Reduce Port; Regular | Lubricated taper Plug valve



S T A N D A R D

Face to Face Dimension	ANSI B16.10
End Flange Dimension	ANSI B16.5, B16.34
Design	ANSI B16.10, API 6D
Basic Design	ANSI API 6D
Fire Test	ANSI API 6FA



GAZAR Plug Valve Venturi Pattern ANSI 600

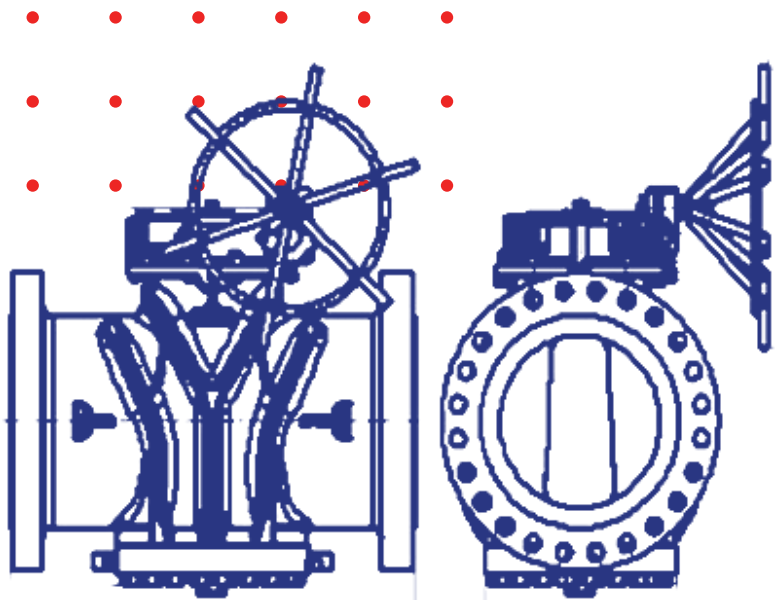

Specifications: Reverse Type | Reduce Port, Venturi
| Lubricated taper Plug valve

S T A N D A R D

Face to Face Dimension	ANSI B16.10
End Flange Dimension	ANSI B16.5, B16.34
Design	ANSI B16.10, API 6D
Basic Design	ANSI API 6D
Fire Safe Design	ANSI API 6FA



GAZAR Jacketed Short Pattern

-
-
-
-
-
-
-
-

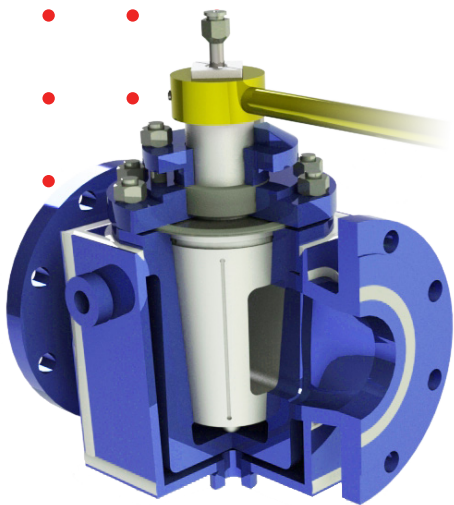

Valves have face-to-face dimensions conforming to BS 5158 PN 10/16, BS 2080 class 150 Short, ANSI B16.10 & APR 6D Class 150 short. These valves are thus interchangeable with equivalent gate valves. Valves have pattern conforming to BS 5353, BS 5158, API 6D & API Short (with Steel Plug). Valves are Normally supplied with drilled class 150 flange having serrated finish raised faces in accordance with ANSI B16.5 most valves on this page can be supplied with flange frillings to BS EN1092-1 PN16. Maximum pressure in jacket 150 lbf/in² . Class 300 valves in size range 25mm to 100mm are available on request.

Jacketed valves with Oversize Flanges

Valves have face to-face dimension conforming to BS 5158 PN 10/16, BS 2080 class 150 short, ANSI B16.10 & API 6D class 150 short. These valves thus interchangeable with equivalent gate valves. Valves have conforming to BS 5353, BS5158, API 6D & API 599 short (with steel plug). Valves have face-to-face dimension confirming to BS EN 558 Basic Series-1. Valves are normally Supplied with drilled class 150 flanges having serrated finish faces in accordance with ANSI B16.5. Maximum pressure in Jacket 150 lbf/in².

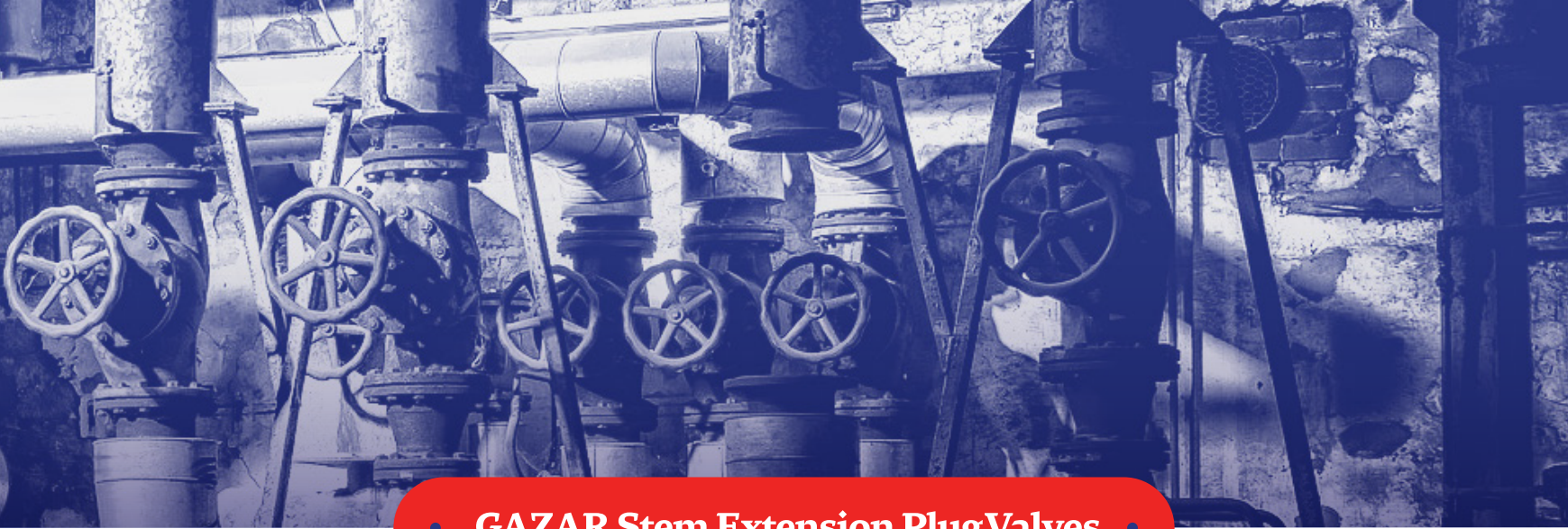

• GAZAR Stem Extension Plug Valves •

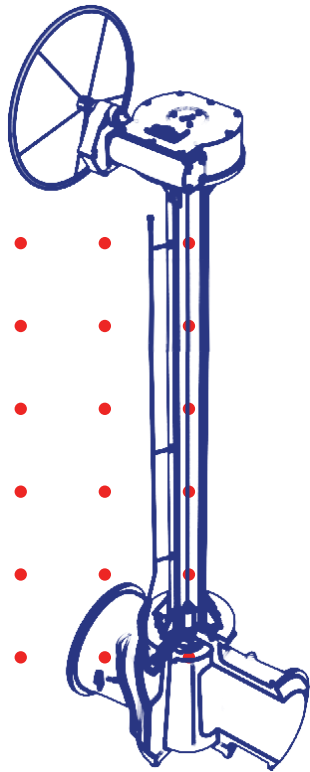

Extended Stem are made to be installed on wrench operated standard stems, in case of buried installation of the plug valve or in case of installation of the valve in plant locations where a normal access of man over is not possible.

Valve extension for underground service include piping for lubrication and are supplied with water tight seals. Extension length should be advised by customer.

Part Name	QTY	Material	Part Name	QTY	Material
Body	1	Carbon Steel	Gland Packing	2	Grafoil
Plug	1	Carbon Steel	Gland	1	Stainless Steel
Stem	1	Stainless Steel	O-Ring (I)	1	Viton
Cover	1	Carbon Steel	O-Ring (II)	1	Viton
Cover Bolt	1S	Carbon Steel	Lock Nut	1	Carbon Steel
Lub. Nipple	1	Stainless Steel	Thrust Bearing	1	Stainless Steel
Gland Bolt	1S	Carbon Steel	Adjusting Bolt	1	Carbon Steel
Press. Button	1	Stainless Steel	Lock Bolt	1	Carbon Steel
Metal Diaphr'm (I)	1	Carbon Steel	Needle Valve	1	Carbon Steel
Metal Diaphr'm (II)	1	Stainless Steel	Gear Operator	1S	Steel
Gasket	1	Grafoil	Check Valve	1	Stainless Steel
Check Valve	1	Stainless Steel	Pipe	1	Steel
Compensator	1	Carbon Steel	Adapter	1	Steel

About GAZAR Control Valve

Performance and safety are two of the key concerns in plants today. Since control valves are the only devices in the control loop that actually move to adjust the process, their performance is fundamental. If they don't perform properly, you can't meet production schedules and maintain product quality. GAZAR control valve (Globe, Rotary) manipulates a flowing fluid, such as gas, steam, water, or chemical compounds, to compensate for the load disturbance and keep the regulated process variable as close as possible to the desired set point. The control valve assembly typically consists of the valve body, the internal trim parts, an actuator to provide the motive power to operate the valve, and a variety of additional valve accessories, which can include positioners, transducers, supply pressure regulators, manual operators, or limit switches.

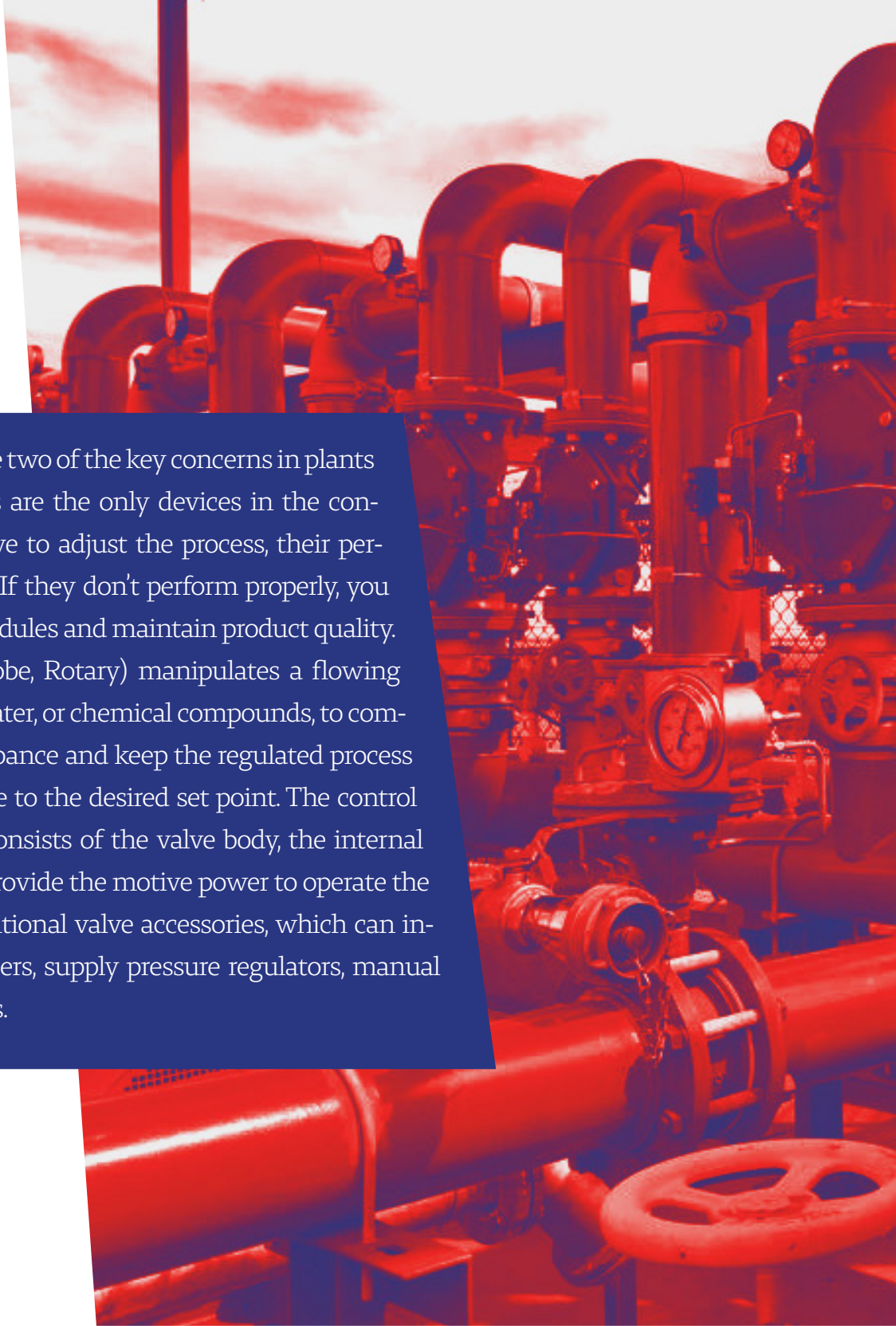



GAZAR Globe Control Valve

Our control valves are available in a variety of sizes (NPS ½ thru 24) and provide users with performance and flexibility. They can help solve an array of application needs from big to small, hot to cold, general to severe. GAZAR globe control valves have a selection of valve cages or plugs that can be interchanged to modify the inherent flow characteristic to linear, equal percentage, or quick opening to meet capacity demands.

GAZAR Rotary Control Valves

Rotary control valves generally have much higher maximum capacity than globe valves for a given body size. This fact makes rotary control valves attractive in applications where the pressure drop is rather small. Rotary control valves include ball, high-performance butterfly (used in throttling applications requiring large flow capacities (from NPS 2 to 72)).

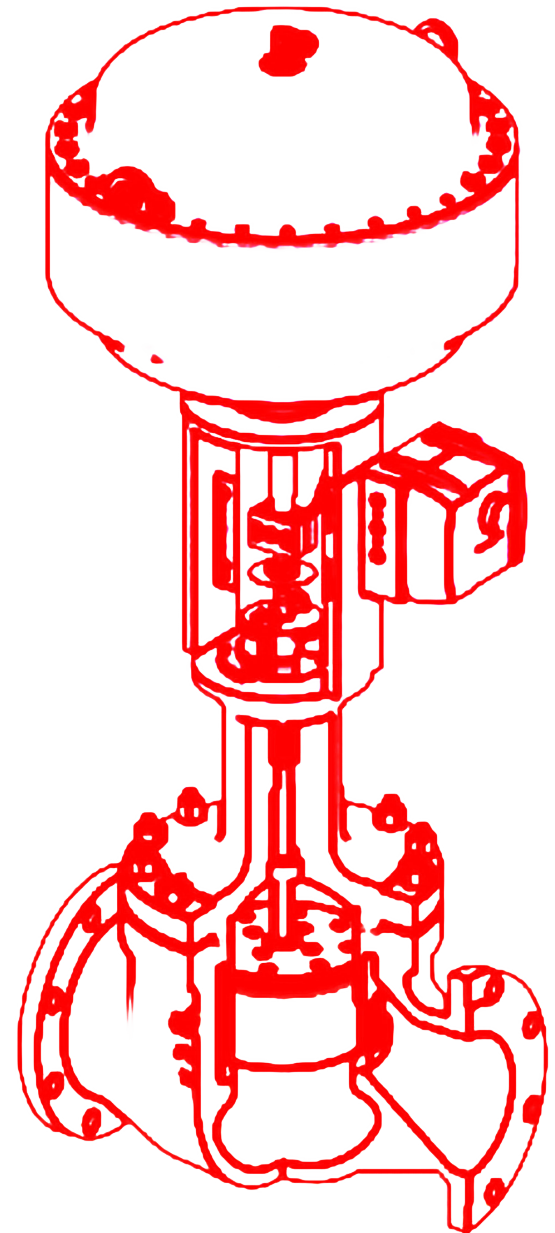

Actuator for Control Valve

Pneumatically-operated control valve actuators are the most popular type in use, but electric, hydraulic, and manual actuators are also widely used. The spring-and-diaphragm pneumatic actuator is most commonly specified due to its dependability and simplicity of design. Pneumatically-operated piston actuators provide high stem force output for demanding service conditions. Adaptations of both spring-and-diaphragm and pneumatic piston actuators are available for direct installation on rotary control valves.

Diaphragm Actuators

Pneumatically-operated diaphragm actuators use air supply from controllers, positioners, or other sources, including various style such as:

1. Direct-acting, in which the increasing air pressure pushes the diaphragm down and extends the actuator stem.
2. Reverse-acting, in which the increasing air pressure pushes the diaphragm up and retracts the actuator stem.
3. Reversible, in which actuators can be assembled for either direct or reverse action.
4. Direct-acting unit for rotary valves, in which the increasing air pressure pushes down on the diaphragm, which, depending on orientation of the actuator lever on the valve shaft, may either open or close the valve.

Piston Actuators

Piston actuators are pneumatically operated using high-pressure plant air up to 150 psig (10.3 bar), often eliminating the need for a supply pressure regulator. Various accessories can be incorporated to position a double acting piston in the event of supply pressure failure, including pneumatic trip valves and lock-up systems.





Manual Actuators

Manual actuators are useful where automatic control is not required, but where ease of operation and good manual control is still necessary.

They are often used to actuate the bypass valve in a three-valve bypass loop around control valves for manual control of the process during maintenance or shut down of the automatic system.

Electric Actuators

Electric actuator designs use an electric motor and some form of gear reduction to move the valve plug. While electric actuators have traditionally been limited to on/off operation, some are now capable of continuous control. The use of brushless motors in electric actuators can reduce or eliminate motor burnout associated with turning the motor on and off rapidly. The initial purchase price still tends to remain above that of pneumatic actuation.



Integrated Accessory Attachment

- Eliminates external tubing reduced height and weight
- Entire actuator top works can be rotated 360° without disassembly

Self-adjusting PTFEV-ring Packing

- Maintenance-free design
- Low friction
- Roller burnished stem reduces friction external leakage, and maximizes packing life beyond what basic polishing can offer from competitors.
- Double wall design
- Small valve travel results in a long bellows life
- Modular design allows for the addition or removal of assembly bellows in the field
- Straight Thread Seat Design No cage, gaskets or seals required trim Fewer spare parts required for maintenance Easy removal even after many years of service.
- Various Noise Attenuation Options Flow Divider I, II, & III (Gases/Vapors) Anti-Cavitation Trims (Liquids) Optional downstream orifice plates



Rolling Diaphragm

Greatly reduces diaphragm wear compared to Stretching diaphragm design used by competitors Diaphragm design results in very small external air loss

Single Bonnet/Yoke Design

Actuator removal without the need to open the valve Bonnet and body of the valve always have same metallurgy Fewer components results in a lower profile valve

Low Lying Guide Bushing

Ensures precise plug alignment for our stem guided

Multiple Plug Designs

- Parabolic: Cost effective & debris friendly
- V-Port: Reduced vibration & debris friendly
- Perforated: Vibration reduction and flow dispersion

GAZAR Internal Strength



Trim For Every Application Obstacles hindering accurate process control can be numerous. GAZAR Control Valves comes equipped with a wide range of available trim options to overcome difficult to control applications.

1. Parabolic Plug
2. VV-Port Guided Plug
3. V Perforated Plug
4. V Multi-Stage Trim
5. Noise Attenuation Trim

Noise Reduction

When not getting noticed is a good thing



A flow divider is an optional internal device used with gases and vapors to help reduce the sound pressure level (SPL) of a valve. By creating an additional stage of pressure reduction inside the valve, it breaks a single large flow stream into multiple smaller flow streams, resulting in reduced noise emissions.

1. Steam Service
2. PSA (Pressure-Swing Adsorption)
3. Toxic and Corrosive Processes
4. Cryogenics

Technical Details



Valve Size: NPS 1/2 to 24 | **Pressure Rating:** ANSI Class 150 to 1500
| End Connection: Flanged: All ANSI Versions, **Welding Ends:** According to ANSI B16.25, **Threated Ends:** Up to NPS 2, ANSI 250 class only | **Materials:** Carbon Steel (A216 WCC, A352 LCC, & A217WC6)
| Temperature Range: -325 to 842°F (-196 to 450°C) | **Internal Leakage Rate:** Class IV,V, or VI according to ANSI/FCI 70-2 and IEC 60534-4 | **Extensions:** Standard/Insulating/Bellows Seal | **Packing:** Spring-Loaded Low Emission V-ring Packing

GAZAR Control Valve Sizing

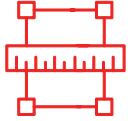

Control valves handle all kinds of fluids at temperatures from the cryogenic range to well over 538°C (1000°F). Selection of a control valve body assembly requires particular consideration to provide the best available combination of valve body style, material, and trim construction design for the intended service. Capacity requirements and system operating pressure ranges also must be considered in selecting a control valve to ensure satisfactory operation without undue initial expense. Following information be provided for any set of conditions deemed important:

- Type of fluid to be controlled
- Temperature of fluid
- Viscosity of fluid
- Concentrations of all constituents including trace impurities
- Process conditions during startup, normal operations, and shutdowns
- Chemical cleaning that may occur periodically
- Specific gravity or density of fluid
- Fluid flow rate I
- Inlet pressure at valve
- Outlet pressure or pressure drop
- Maximum permissible noise level, if pertinent, and the measurement reference point
- Degrees of superheat or existence of flashing, if known
- Inlet and outlet pipeline size and schedule
- Special tagging information required
- Cast body material (ASTM A216 grade WCC, ASTM A217 grade WC9, ASTM A351 CF8M, etc.)
- End connections and valve rating (screwed, Class 600 RF flanged, Class 1500 RTJ flanges, etc.)
- Action desired on air failure (valve to open, close, or retain last controlled position)
- Instrument air supply available
- Instrument signal (3 to 15 psig, 4 to 20 mA, HART, etc.)

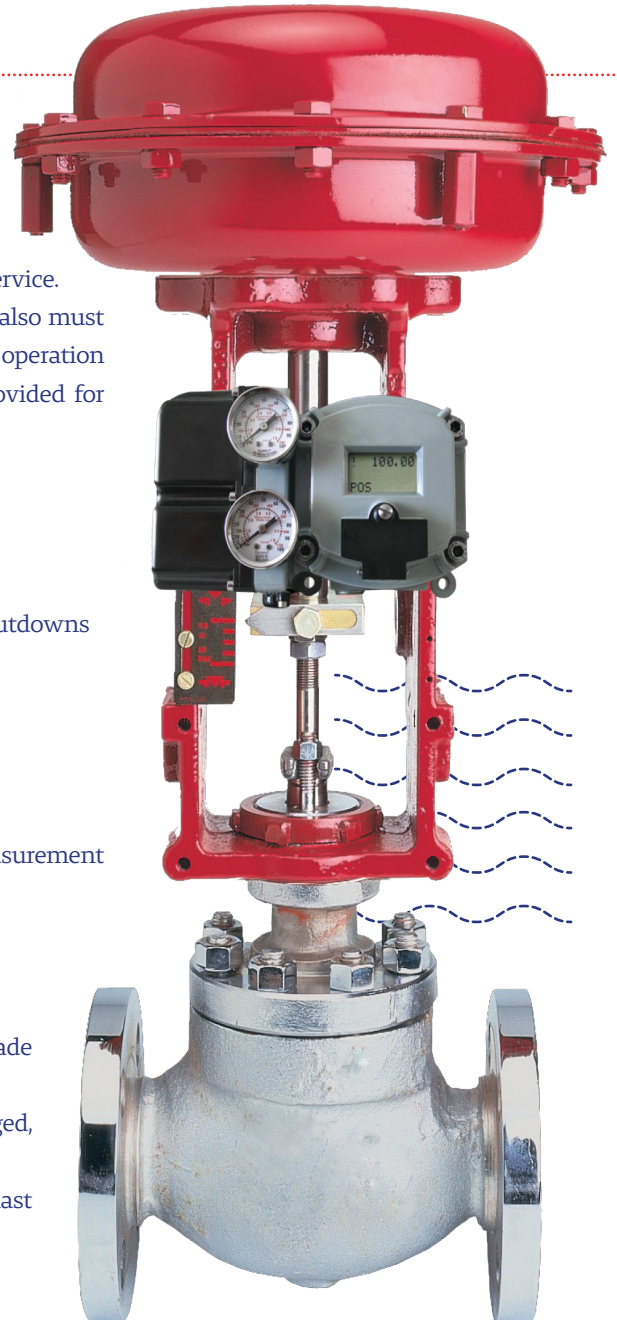



Control Valve, Design BF

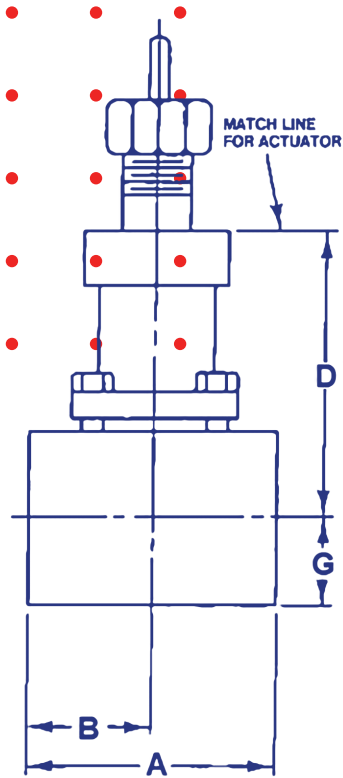

Specifications: Globe-Style, Economical | Stem Guide Equal | Percentage – Flow Up | Bullet Form in Steel or Stainless Steel Bodies | Equal to Maximum Inlet pressure 1500 Psig From (-20 to 450°F) | Screwed or Socket weld End Connections

Description	Material		
	Standard	NACE-MR0175	NACE-MR0175
Body	WCB	WCB	316 SS
Bonnet	WCB	WCB	316 SS
Stem	316 SS	316 SS	316 SS
Seat Ring	316 SS	316 SS	316 SS
Valve Plug	316 SS	316 SS	316 SS
Guide Bushing	17-4 PH SS	17-4 PH SS	Hastelloy C

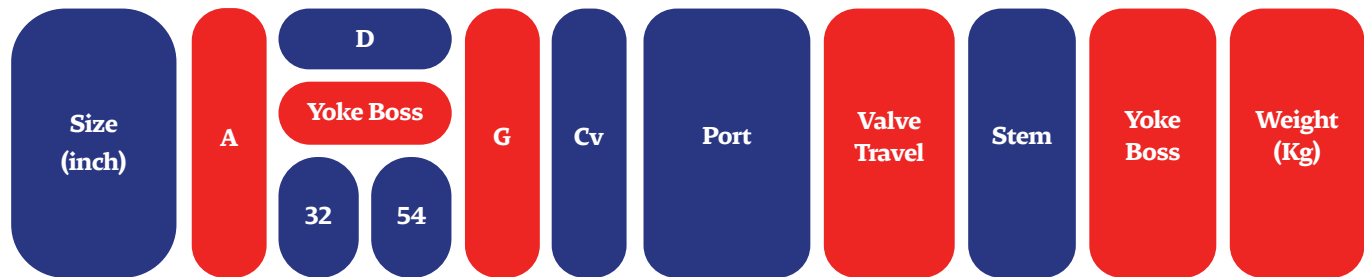

1/2"	102	95	106	35	14 2.5	6.4 9.5	19	9.5	32 Or 54	7
------	-----	----	-----	----	-----------	------------	----	-----	----------	---

3/4"	105	95	106	35	14 3 4	6.4 9.5 12.7	19	9.5	32 Or 54	9
------	-----	----	-----	----	--------------	--------------------	----	-----	----------	---

1"	127	98	110	38	14 3 4.7 7.4	6.4 9.5 12.7 19.1	19	9.5	32 Or 54	11
----	-----	----	-----	----	-----------------------	----------------------------	----	-----	----------	----

$B = \frac{A}{2}$

Maximum Flow Coefficients

Other materials upon request

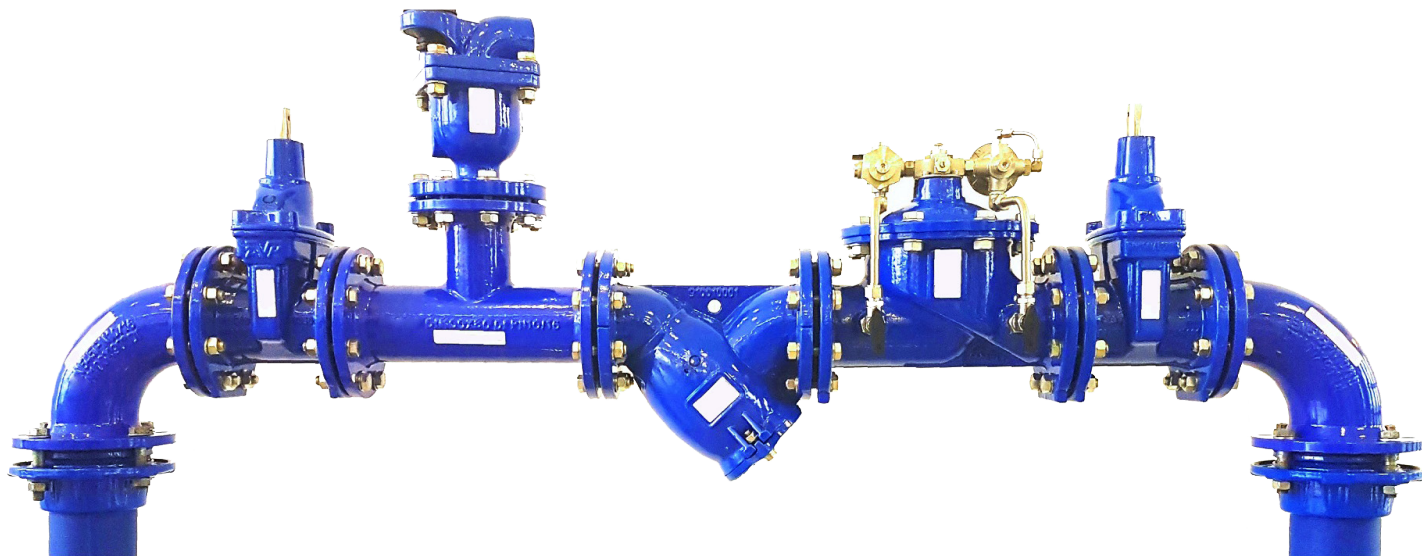



Control Valve, Design BT

-
-
-
-
-
-
-
-
-

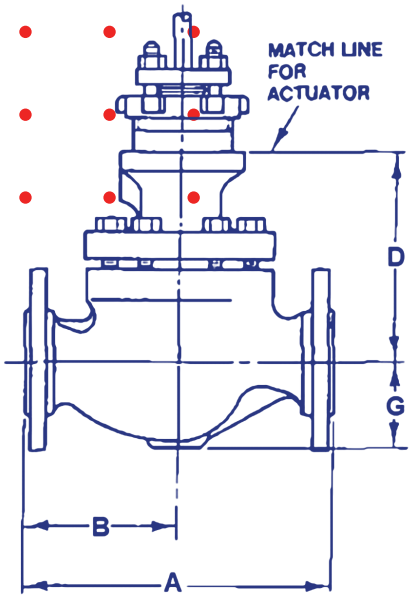

Specifications: Bodies are Globe-Style Valves | Full Capacity Trim: Quick Opening, Linear or Equal Percentage | Bullet Type, stem guide

Description	Material		
	Standard	NACE-MR0175	NACE-MR0175
Body	Cast Iron	WCB Steel	316 SST (CF8M)
Cage	17-4 PH SST	316 SS	316 SS
Seat Ring	410 or 416 SS (Hardened)	316 SS / Alloy 6 Seat	316 SS
Valve Plug	416 SS (Hardened)	316 SS / Alloy 6 Seat	316 SS
Guide Bushing	17-4 PH SST	Alloy 6	Alloy 6

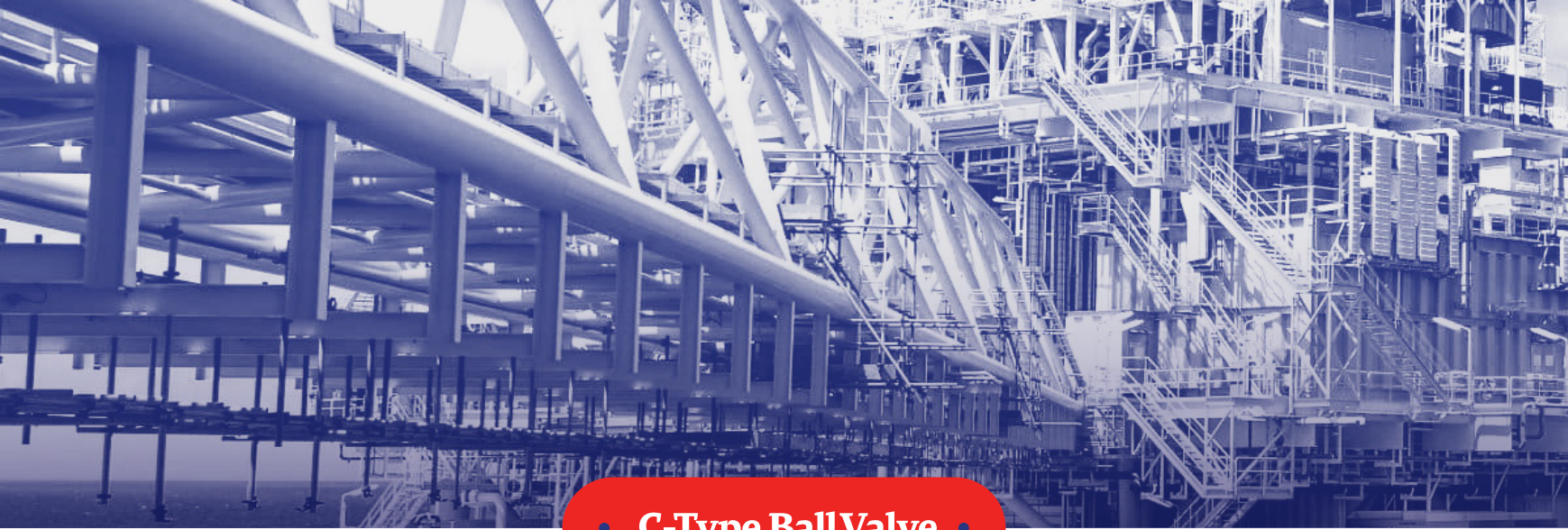

C-Type Ball Valve

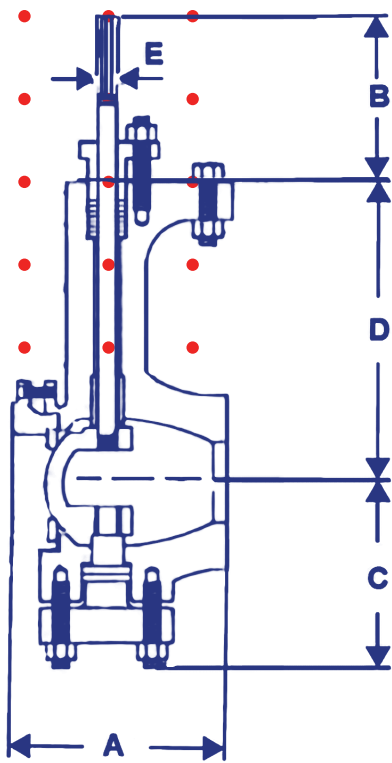

Specifications: Modified equal percentage | PTFE Packing: -46 to 232 C | Graphite Ribbon Packing: -198 to 427 C | -46 to 260 C, 150 & 300 LB

Description	Material		
	Standard	NACE-MR0175	Stainless steel
Body	ASTM A216 Gr. WCC	ASTM A216 Gr. WCC	ASTM A351 Gr.CF8M
V-notch Ball	ASTM A351 Gr.CF8M	ASTM A351 Gr.CF8M	ASTM A351 Gr.CF8M
Shaft	S20910/Monel	S20910	17-4PH
Bearing	Peek/PTFE	PEEK/PTFE	PEEK/PTFE
Valve Shaft	PTFE	PTFE	PTFE



• Eccentric Ball Valves •

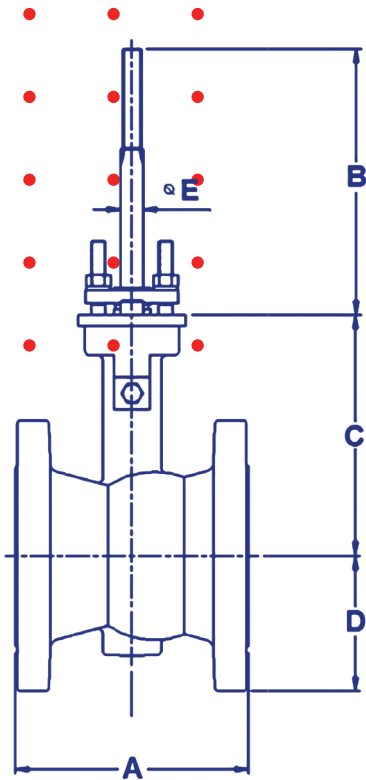

Specifications: Modified linear | PTFE V-ring: -198 to 232 C | Graphite: -198 to 425 C, 150 & 300 LB

Description	Material		
	Standard	NACE-MR0175	Stainless steel
Body	ASTM A216 Gr. WCC	ASTM A216 Gr. WCC	ASTM A351 Gr.CF8M
Valve Plug	Chrome-Plated 316 SS	Alloy 6	316 SS
Shaft	316 SS	316 SS	316 SS
Guide Bushing	440 SS/Alloy 6	316 SS	PEEK/PTFE/Alloy 6
Valve Shaft	S20910 (Nitronic 50)	S20910 (Nitronic 50)	S20910 (Nitronic 50)



Control Valve, Design HP

- • •
- • •
- • •
- • •
- • •
- • •

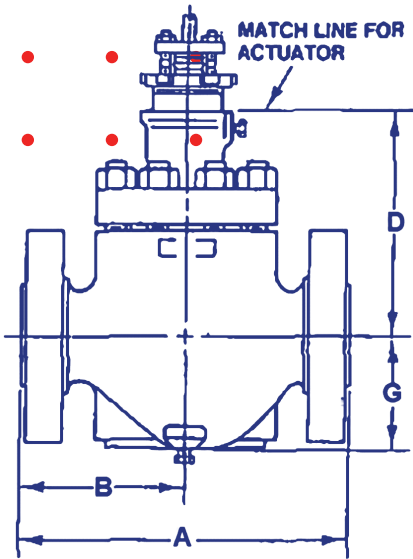

Specifications: High-Pressure, Globe Valve | Metal Seats, Cage Guide | 2160 psi (149 bar) For Two | Stage Cage and 3000 psi (207 bar) | For Three-Stage Cage | Equal percentage, Modified Equal Percentage, Linear

Description	Material		
	Standard	NACE-MR0175	NACE-MR0175
Body	WCB steel	WCB steel	316 Stainless Steel
Valve Plug	442 Stainless Steel	17-4PH stainless steel with Alloy 6	316 Stainless Steel with Alloy 6
Cage	17-4PH Stainless steel	17-4PH Stainless steel	316 Stainless Steel Electrolyzed
Seat Ring	416 Stainless Steel	Alloy 6	Alloy 6
Seat Ring Retainer	416 Stainless Steel	Inconel 718 Heat Treated Electrolyzed	Inconel 718 Heat Treated Electrolyzed



Control Valve, Design PT

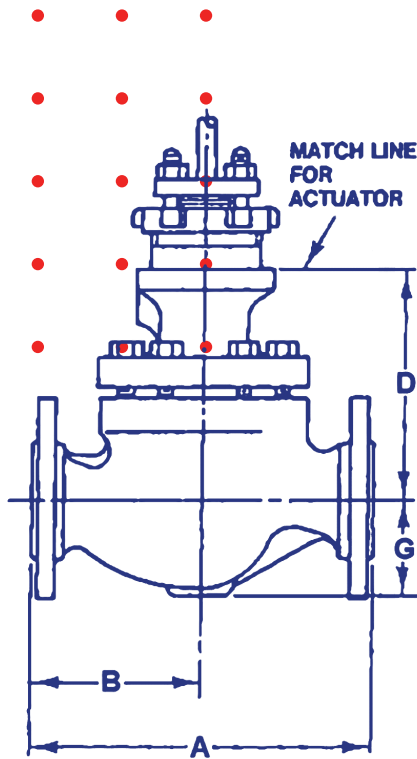

Specifications: Globe Style | Cage Guide | Quick- Opening, Linear, Equal Percentage | Anti-Noise: Always Up | Anti-Cavitation: Always Down | High-temperature | High-Pressure is available too

Description	Material		
	Standard	NACE-MR0175	NACE-MR0175
Body	WCB Carbon steel	LCB Carbon Steel	316 Stainless Steel
Valve Plug	416 Stainless Steel	420 Stainless Steel	316 Stainless Steel
Cage	17-4PH Stainless steel	17-4PH Stainless steel	316 Stainless Steel with Electroless Nickel
Disk Seat	316 Stainless Steel	-	316 Stainless Steel
Seat Ring	410 or 416 Stainless Steel	17-4PH Stainless steel	316 Stainless Steel

About Butterfly Valve

Butterfly valve is a quarter-turn rotational motion valve that is used to stop, regulate, and start flow. Butterfly valves are easy and fast to open. A 90° rotation of the handle provides a complete closure or opening of the valve. Large Butterfly valves are usually equipped with a so-called gearbox, where the hand wheel by gears is connected to the stem. This simplifies the operation of the valve, but at the expense of speed.





Types of Butterfly valves

Butterfly valves has a short circular body, a round disc, metal-to-metal or soft seats, top and bottom shaft bearings, and a stuffing box. The construction of a Butterfly valve body varies. A commonly used design is the wafer type that fits between two flanges. Another type, the lug wafer design, is held in place between two flanges by bolts that join the two flanges and pass through holes in the valve's outer casing. Butterfly valves are even available with flanged, threaded and butt welding ends, but they are not often applied.

Butterfly valves possess many advantages over gate, globe, plug, and ball valves, especially for large valve applications. Savings in weight, space, and cost are the most obvious advantages. The maintenance costs are usually low because there are a minimal number of moving parts and there are no pockets to trap fluids.

Butterfly valves are especially well-suited for the handling of large flows of liquids or gases at relatively low pressures and for the handling of slurries or liquids with large amounts of suspended solids. They are built on the principle of a pipe damper. The flow control element is a disk of approximately the same diameter as the inside diameter of the adjoining pipe, which rotates on either a vertical or horizontal axis. When the disk lies parallel to the piping run, the valve is fully opened. When the disk approaches the perpendicular position, the valve is shut. Intermediate positions, for throttling purposes, can be secured in place by handle-locking devices.



Compliance with the Standards and Directives

Concentric butterfly valve is a wafer & Lug Type with flange locating holes, and Companion lug version for dead-end service and other flange requirements. Concentric butterfly valve are tested to 110% of full pressure rating before shipment. A major design advantage of our valve product lines is international compatibility.

The same valve is compatible with most world flange standards – ANSI Class 125/150, BS 10 Tables D and E, BS 4504 NP 10/16, DIN ND 10/16, AS 2129 and JIS10. In addition the valves are designed to comply with ISO 5752 face-to-face and ISO 5211 actuator mounting flanges. Therefore, one valve design can be used in many different world markets. All Butterfly Valve handles, manual gear Operators and pneumatic and electric Actuators mount directly to valves.

Recommended Specifications



1. Wafer or lug bodies, one or two pieces stem, concentric butterfly valve
2. Stem to disc with no possible leak paths in disc/stem connection.
3. with flange locating holes that meet ANSI Class 125/150 (or BS 10 Tables D & E, BS 4504 NP 10/16, DIN ND 10/16, AS 2129 and JIS 10) drillings.
4. Stem mechanically retained in body neck and no part of stem or body exposed to line media.
5. Spherically machined, hand polished disc edge and hub for minimum torque and maximum sealing capability
6. Equipped with non-corrosive bushing and self-adjusting stem seal.
7. Bi-directional and tested to 110% of full rating.
8. Field adjustment necessary to maintain optimum field performance.



Material Selection



Body	Seat	Stem	Disk
Cast Iron ASTM A126 Class B	Buna-N – Food Grade	Coated Carbon Steel	Aluminum Bronze ASTM B148-954
Ductile Iron ASTM A536	EPDM – Food Grade	ASTM A582 Type 416	Coated Ductile Iron ASTM A536 Gr. 65-45-12
Cast Steel ASTM A216 WCB	FKM	ASTM A276 Type 304	Ductile Iron, Nylon 11 Coated, ASTM A536 Gr. 65-45-12
Aluminum ASTM B26	White Buna-N – Food Grade	ASTM A276 Type 316	316 Stainless Steel ASTM A351 CF8M
-	-	-	C-276 ASTM B575 Alloy N10276

Triple Offset

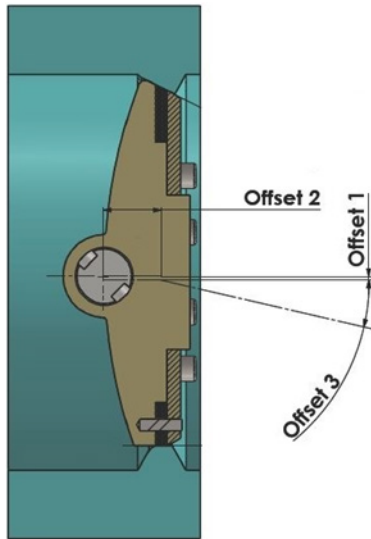

Double Offset

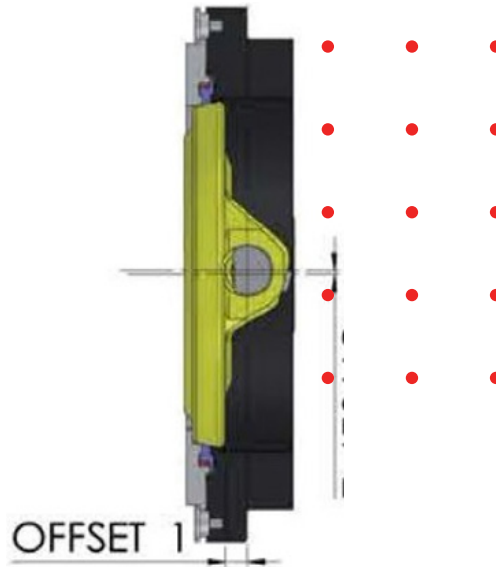

Single Offset

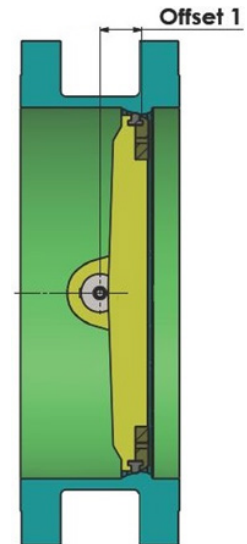

With body design Lug & Flange

General Characteristics



Triple offset

- DN 50–1220 (NPS 2–48)
- ASME Rating 150-300-600-900
- Triple offset design
- Body design: Lug & Double Flange
- Minimal opening, closing friction
- Metal / metal seat
- Maximum working pressure: 50 Bar
- Working temperature range: -100°C to 500°C

Double & Single offset

- DN 50–1625 (NPS 2–64)
- ASME Rating 150-300-600-900
- Double offset design
- Body design: Lug & Double Flange
- Minimal opening, closing friction
- Soft seat
- Maximum working pressure: 50 Bar
- Working temperature range: -100°C to 500°C

Design Benefits



Split shaft design ensures high Kv (Cv) value and lower pressure drop.

A) Self-loaded Stuffing Box As Option

Perfect tightness of shaft, no up-movement of shaft as well as reduced torque for low pressure applications is guaranteed by self-loaded stuffing box in the body neck.

B) Graphite Packing

As standard, a graphite packing is installed around the upper shaft providing additional safety in case of medium overheating.

C) Adjustable Shaft Packing

Shaft packing system allows for easy access to adjusting the hex head nuts without requiring removal of the actuator.

D) Blow-out Proof Stem

A retaining ring is installed between the machined shaft groove and gland retainer step.

E) Shaft Bearings

Top and bottom bearing consisting of TP Lugs fabric liner providing for excellent resistance to distortion, high temperatures and mechanical loading forces.

F) Spiral Gasket

Spirally wound stainless steel band with a soft graphite filler guarantees a perfect seal even with large temperature and pressure fluctuations inside the pipe. Extended neck ensures pipe insulation.

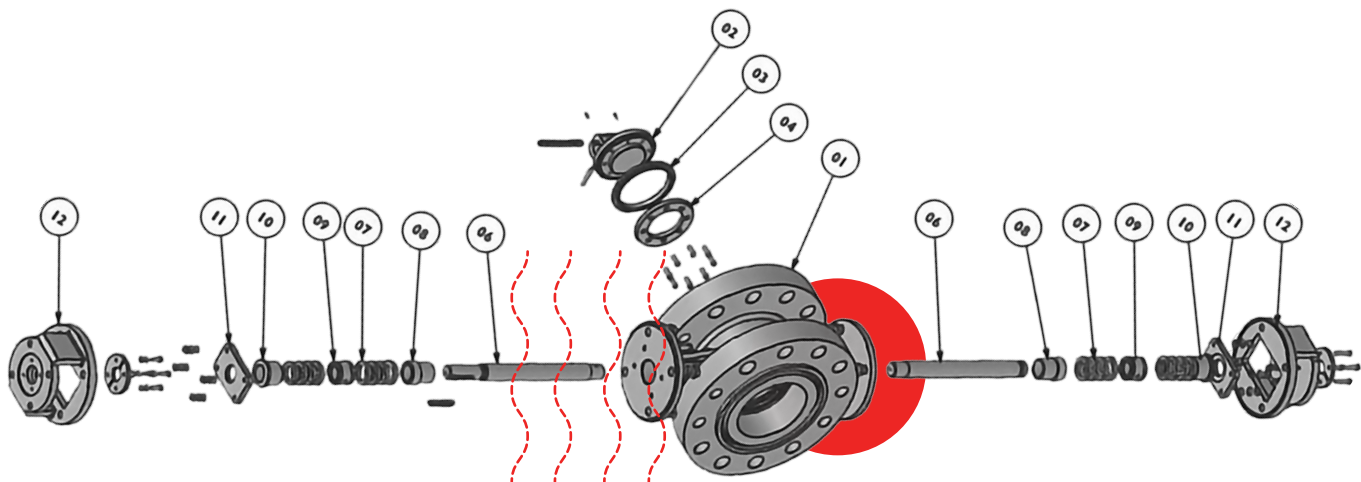

Material Selection



Part Name	Material	Part Name	Material
Body	1. Stainless steel AISI 904L 2. Low carbon content steel A352 LCC 3. Carbon Steel A216 WCB 4. Stainless Steel A351 CF8M	Retaining Ring	Stainless steel AISI 316
		Stem	Stainless steel AISI 420 or (2205 Duplex)
Disc	1. Stainless steel AISI 904L 2. Carbon steel A216 WCB 3. Carbon steel A216 WCB + Stellite® 4. Stainless steel AISI 316B 4. Stainless steel AISI 420 5. Stainless steel (CF8M)	Packing	Braided Graphite
		Body Bushing	Stainless steel AISI 316
Seat	-	Lantern Ring	A105 + ENP
Cage	A 105	Gland Bushing	Stainless steel AISI 316
		Gland	Stainless steel AISI 316

| All discs are nitride (on request can be coated with Stellite) |

Disadvantages of Butterfly valves



- Disc movement is unguided and affected by flow turbulence
- Throttling service is limited to low differential pressure
- Cavitation and choked flow are two potential concerns

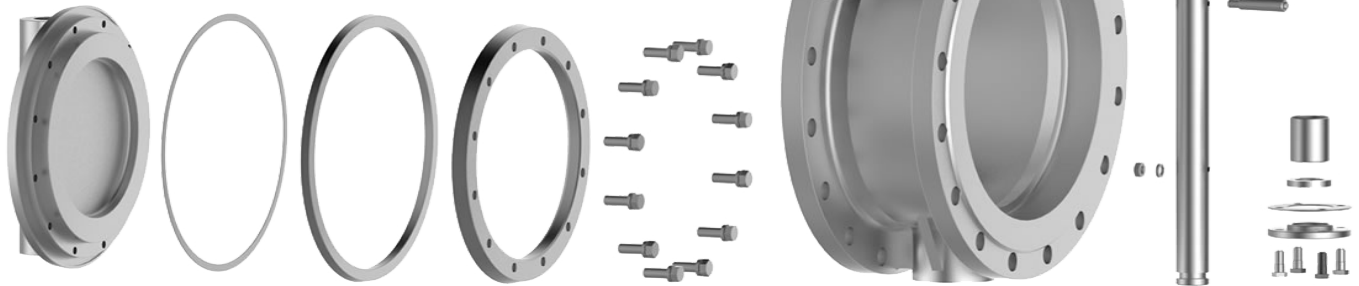

About Through Conduit Gate Valves

Through Conduit Slab Gate Valves can be used in many applications. Our valves have been installed in numerous projects around the world, in on/off, ESDV (Emergency Shutdown Valve) and HIPPS (High Integrity Pressure Protection System) valve applications.

Designing for increasing maximum allowable pressures for Slab Gate Valves, through continuous research and development to meet our clients' new requirements, is one of our major objectives. The resulting design expertise guarantees the product reliability improvement year by year.





Acting design

The Through Conduit Slab Gate Valve is designed and manufactured with the rising stem to accommodate the floating movement of the gate. During the valve operation, the line fluid fills the Bore cavity. The fluid pressure in the bore cavity generates a vertical force on The stem that pushes the trim from bottom to top. In case of emergency, This force is used to assist the actuator spring to bring the valve gate to the required Failure mode position.



Seat Sealing

Slab gate valve construction includes spring energized floating seats, which provide positive Seating on both sides, regardless of upstream or downstream pressure conditions. The seat seals are spring energized to ensure sealing under low pressure conditions. When the line pressure increases, the seat-to-gate contact pressure increases accordingly to provide positive shutoff. Since both seats are individually energized by differential pressure across the seat itself, the valve cavity can be vented when the upstream and/or downstream side is pressurized. The valve exhibits identical performance, regardless of direction of flow, and/or orientation of differential pressure. Different solutions are available for seat-to-body gaskets, depending on Service fluid type, pressure, and temperature conditions.



Design feature

S.M.P Co manufactures a full range of though conduit gate valves for production, processing and transmission applications. Though conduit gate valves provides superior bubble tight sealing capabilities in gas service and unmatched robustness in harsh services With high pressure, high temperature and sand service. GAZAR can supply Through Conduit Gate Valves in different configurations, slab type and double expanding type. GAZAR through Conduit Gate Valves comply with following industry standards:





Main Design Features

API 6D or API 6A

Metal Seat ASME B16.34

Fire Safe Full Bore

Bidirectional/Unidirectional

Self-Relieving Anti-Static device

Anti-blow out stem

Standard-Reverse



Accessories

Vent & Drain

Plugged Flanged With valve

Any type of Connection Upon request

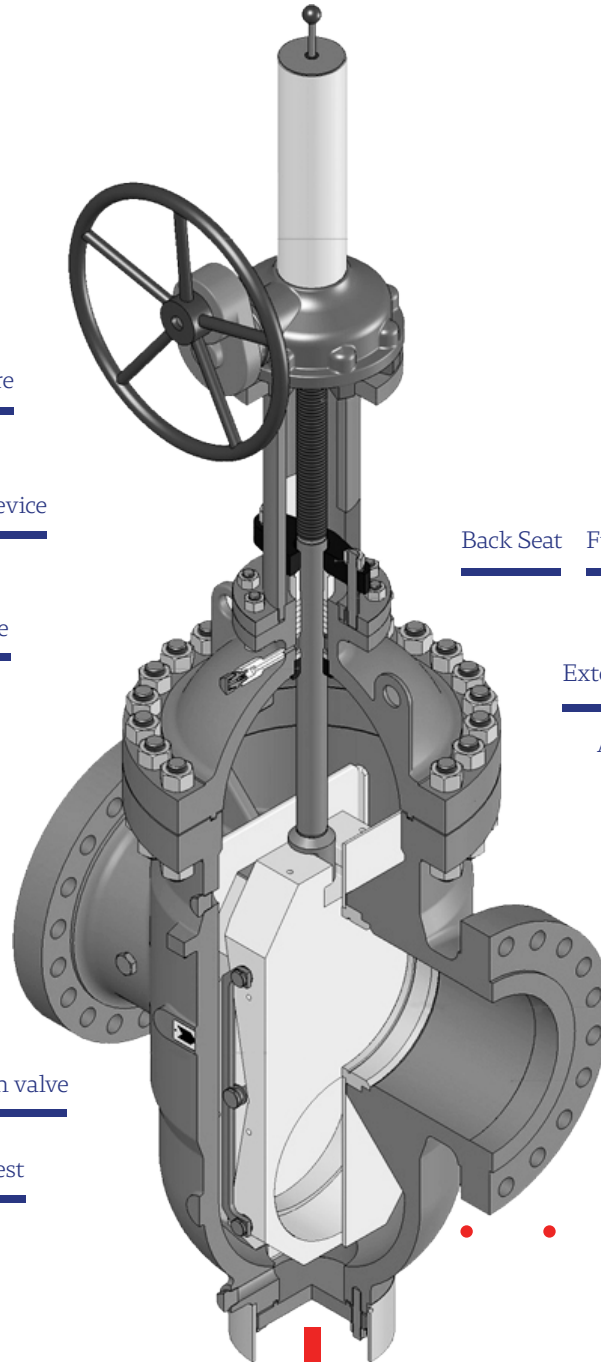

Special Features

NACE Requirement

Negligible pressure drop

Pig ability Special Bore

Back Seat Full/partial cladding

Equalizing hole in gate

Extended Stem Double Block & Bleed

Ad hoc design for installation and horizontal stem or vertical pipeline

Ad hoc engineering to suit customer

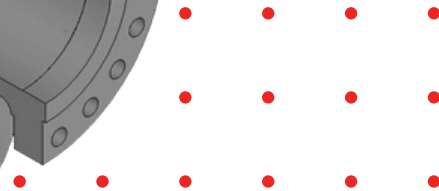



GAZAR Models

Model No.	Standard	Gate Type	Valve Type	Size
SMP-C-1	API 6D	Expanding	Outside Screw, Rising Stem	4" and Smaller
SMP-C-2	API 6D	Expanding	Outside Screw, Rising Stem	6" and Smaller
SMP-C-3	API 6D	Slab	Outside Screw, Rising Stem	All
SMP-C-4	API 6D	Slab	Inside Screw, Not-Rising Stem	All
SMP-C-5	ASME B16.34	Parallel Slide	Inside Screw, Not-Rising Stem	All

1

Through Conduit Slab Gate Valves API 6D

Features



Full bore | Pig gable | Double block and bleed, double isolation | Bubble tight | Bolted bonnet | Rising stem | Stem back-seat | Soft or metal seated

Applicable Standards

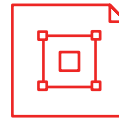

API 6D ISO 14316 | ANSI B16.34 | ANSI B16.10 | NACE MR0175 / ISO 150156

Range



2" to 42" Class 150 | 2" to 42" Class 300 | 2" to 42" Class 600 | 2" to 30" Class 900

Ends



Flanged to ANSI B16.5 - B16.47 - MSS SP-44 | Butt weld ends to ANSI B16.25

Materials



Carbon steel | Low temperature carbon steel | Stainless austenitic and super austenitic | Stainless duplex and super duplex | Nickel super alloys (Montel, Inconel 625, and Hastelloy)

Operators

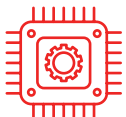

Manual gear | Electric multi turn | Hydraulic double acting and fail close | Pneumatic double acting and fail close

Options



Overlay Inconel 625 | Reverse gate for fail close service | Inside screw



2

Through Conduit Double Expanding Gate Valves API 6D



Features



Full bore | Pig gable | Double block and bleed, double isolation | Bubble tight | Bolted bonnet | Rising stem | Soft or metal seated | Fire-safe | Fugitive emission

Applicable Standards

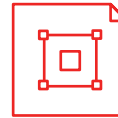

API 6D ISO 14316 | ANSI B16.34 | ANSI B16.10 | API 6FA | NACE MR0175 / ISO 150156

Range



2" to 42" Class 150 | 2" to 42" Class 300 | 2" to 42" Class 600 | 2" to 30" Class 900

Ends



Flanged to ANSI B16.5 - B16.47 - MSS SP-44 | Hub connectors | Butt weld ends to ANSI B16.25

Materials



Carbon steel | Low temperature carbon steel | Stainless austenitic and super austenitic | Stainless duplex and super duplex, Nickel super alloys (Monel, Inconel 625, Hastelloy)

Operators

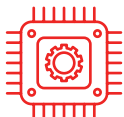

Manual gear | Electric multi turn | Hydraulic double acting and fail close | Pneumatic double acting and fail close

Options



Inside screw | Overlay Inconel 625

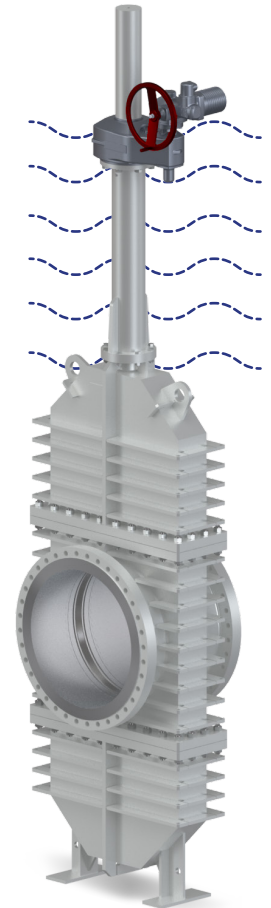

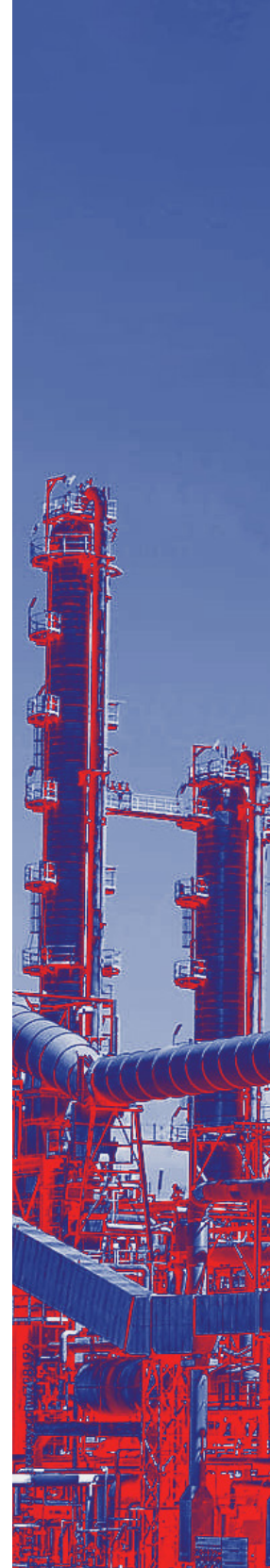
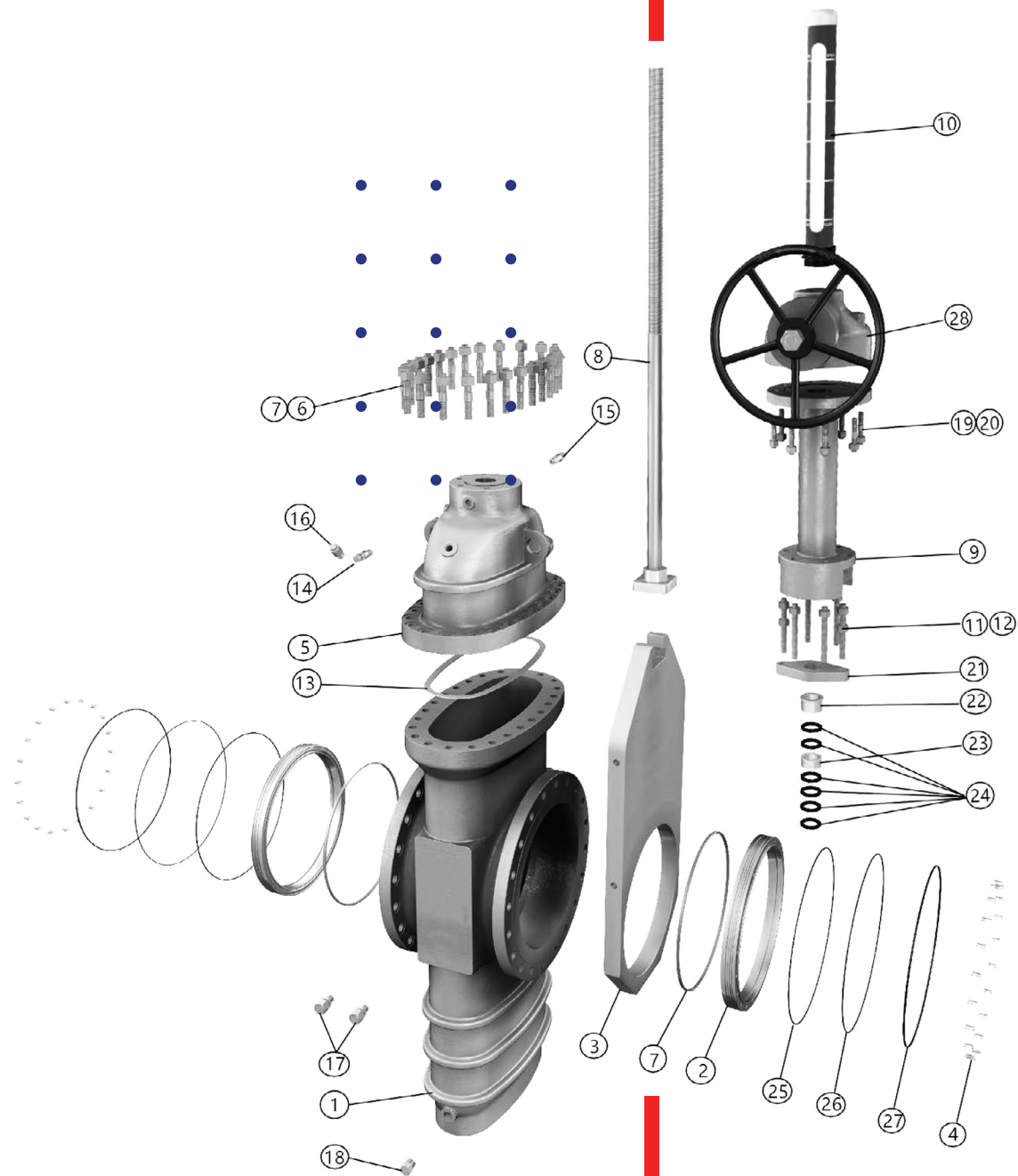



Item No.	Part Name	Item No.	Part Name
1	Body	15	Plug
2	Seat	16	Vent Valve
3	Disk	17	Injection Fitting
4	Spring	18	Drain Plug
5	Bonnet	19	Gearbox Stud Bolt
6	Bonnet Bolt	20	Gearbox Stud Nut
7	Bonnet Nut	21	Gland Flange
8	Stem	22	Gland
9	Welding Yoke	23	Lantern Ring
10	Stem Cover	24	Packing
11	Gland Stud Bolt	25	Graphite Wire Rod
12	Gland Stud Nut	26	Seat O-Ring
13	Gasket	27	Seat Gasket O-Ring
14	Packing Fitting	28	Gear Box

About Swing Check Valve

Swing check valves, like all check valves, are used to prevent back flow in the line. The pressure of the fluid passing through a system opens the valve, while any reversal of flow will close the valve. The swing check valve functions by allowing flow forces to move the closure element, it is a hinged clapper which swings or rotates around a supporting shaft. GAZAR Swing Check valves are manufactured and modified to the latest edition of API Standard 600/ASME B16.34 and tested to API Standard 598.

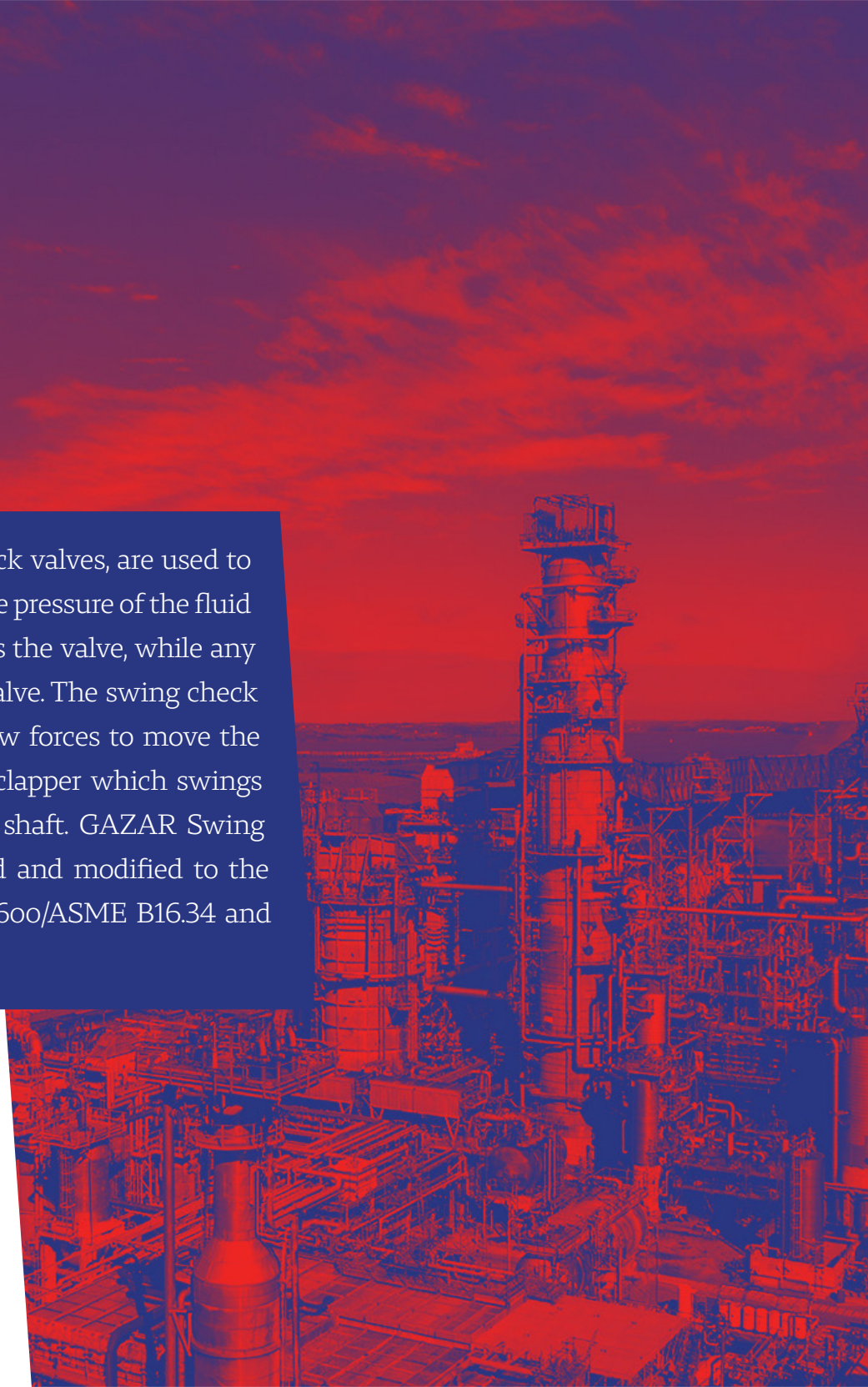



Acting design

Swing Check Valves are normally operated by the flow, if the flow stops and backs up, the valve will then be closed by the back-pressure.



Body

The body is full ported and spherical in form. The design utilizes large radiuses which allow for the stresses, flow resistance and turbulence to be kept to a minimum. Bosses are provided for optional drains.



Body-cover Joint

Standard body-cover joints of our swing check valves are machined as follows:

- **Pressure Class:** 150, 300, 600, 900 over.
- **Joint Design:** Male-and-Female, Ring Type Joint
- * Pressure Class 600 also available in Ring Type Joint.
- ** GAZAR can supply any style of gasket required by customer.



Hinge Assembly

The hinge arm pivots on the hinge pin which is located near the disc's center of gravity. Body penetration for the hinge pin is sealed with a soft steel gasket and flanged plug. The hinge arm is designed to withstand the shock load of quick closing to insure a longer life and continued shut-off. The hinge arm also has an integral disc stop that provides a positive stop in the open position.

Disc



Each disc's seating surface is precision ground and mated to the seat ring for insurance of a positive shut off. The disc is secured to the hinge arm with the disc nut and pinned to prevent disengagement during service. We can provide either integral or overlaid seat facings at customer's request.

Seat Ring



Seat rings are designed to greatly reduce and/or prevent any turbulence and avoid damages due to corrosion. The seat rings are forged or rolled in one piece and then seal welded and overlaid, if required. After welding and all required heat treating, the seat ring faces are machined, thoroughly cleaned and inspected before leaving for assembly.

Bolts And Nuts

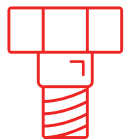

For normal service conditions, ASTM A194 Class 2H and ASTM A193 Grade B7 nuts and stud bolts are furnished. If specified for high temperature service conditions, ASTM A194 Class 4 and ASTM A193 Grade B16 nuts and stud bolts are furnished. Standard bolting furnished for our stainless steel valves consists of ASTM A194 Class 8 and ASTM A193 Grade B8 nuts and stud bolts. GAZAR can supply any bolting as requested by the customer.

End Connections



Our standard production covers valves with:

- Flange ends with Raised Face (RF), Flat Face (FF) or Ring Type Joint (RTJ) that conform to B16.5.
- Butt-welding ends (BW) that conform to B16.25.
- All face-to-face/end-to-end dimensions conform to B16.10.
- Other special end connections are supplied according to customer's requirements.

Accessories/optional Designs



Counterweight features are available as an accessory. Piston, tilting disc or API6D designs are also available to meet the customers' requirements. Drains and bypasses are available as specified by the customer.



• **Gazar Swing Check Valve** •

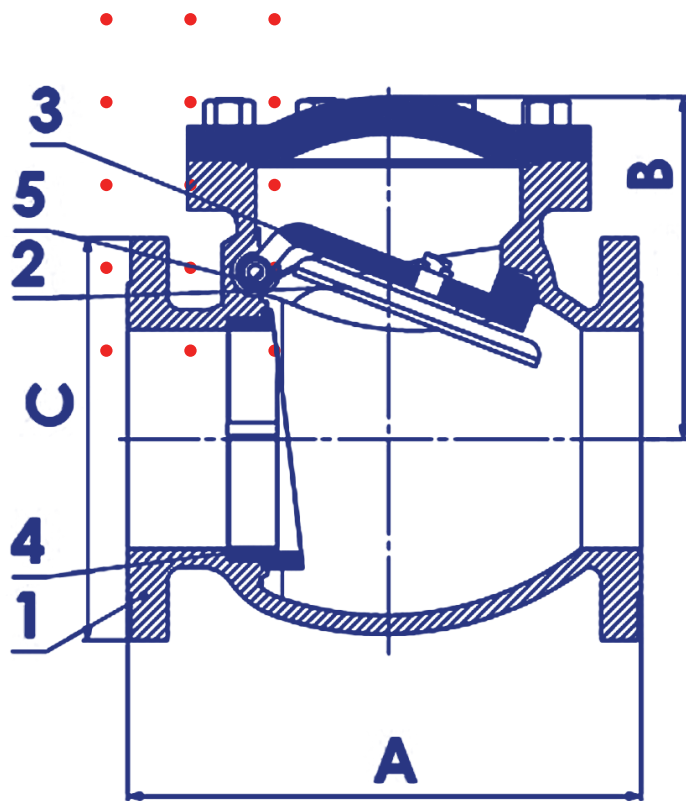

Specifications: Swing Check valve | Bolted Cover | Flanged Ends | Full Bore

S T A N D A R D

Face to Face Dimension	API 6D
End Flange Dimension	ANSI B16.5
Basic Design	API608 / API6D
Fire Safe Design	API607

About Dual Plate Check Valve

Dual Plate check valves have a solid thermoplastic body with a very thin “wafer” profile that makes them an ideal check valve for applications that require valves with short takeout lengths. Wafer check valves are used in applications where it is essential to ensure fluid flow passes in only one direction.





Acting design

Dual disc wafer check valves are the clear choice for many piping engineers because of their proven reliability, ease of installation and low ΔP . Now, they are available in a full port design that dramatically improves performance. They are ideal for application in vacuum pumps, compressed air and gas systems as well as in water systems where low head loss and elimination of water hammer are desirable.

Standards

- Design API 6D, ISO 14313, ASME B16.34
- Face to Face size ASME B16.10
- End Type ASME B16.5 & B16.47 & ISO 7005
- NACE MR0175
- Test and Inspection API 598
- Fire safe valve design. Design verification through tests and certificates according to API 6FA and ISO 10497 standards

The torsion spring is designed to maximize reliability and minimize pressure loss and quickly close the check valve at zero flow to prevent slamming and water hammer commonly associated with many Types of other check valves.

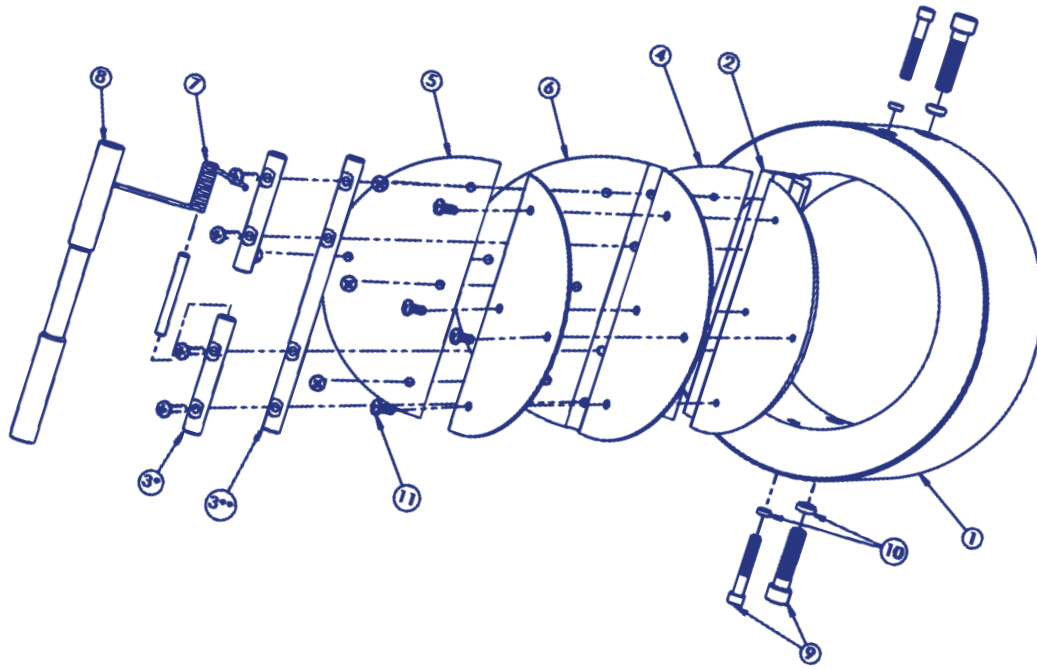

Part No	Part Description	Material
1	Wafer Body (Solid Body Style Shown)	"Cast Iron / Ductile Iron / Carbon Steel / SS304 / SS316 / Alu-Bronze"
2	Wing Support	-
3*	Spring Pin	Stainless Steel (SS304 / SS316)
3**	Wing Pin	-
4	Disc	"Ductile Iron / Carbon Steel / Bronze / SS304 / SS316 / Alu-Bronze"
5	Back-up Disc	-
6	Elastomer Seal	-
7	Spring Pin	Stainless Steel (SS304 / SS316)
8	Limiter	-
9	WS/LM Fastener	-
10	Sealing Washer	-
11	Sealing Washer	-



GAZAR Dual Plate Check Valve

-
-
-
-
-

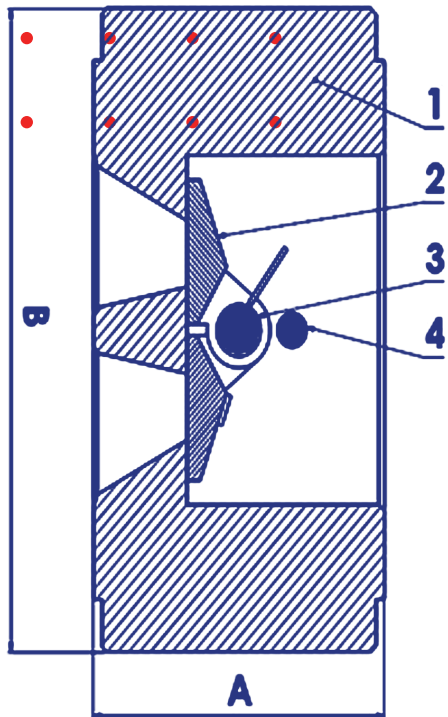

Specifications: Dual Plates | Wafer Type

S T A N D A R D

Face to Face Dimension

API 6D

End Flange Dimension

ANSI B16.5

Design

ANSI B16.34

Basic Design

API608 / API6D

Fire Safe Design

API607



